

Errata

Title & Document Type: E1426A Service Manual

Manual Part Number: E1426-97003

Revision Date: January 1999

HP References in this Manual

This manual may contain references to HP or Hewlett-Packard. Please note that Hewlett-Packard's former test and measurement, semiconductor products and chemical analysis businesses are now part of Agilent Technologies. We have made no changes to this manual copy. The HP XXXX referred to in this document is now the Agilent XXXX. For example, model number HP8648A is now model number Agilent 8648A.

About this Manual

We've added this manual to the Agilent website in an effort to help you support your product. This manual provides the best information we could find. It may be incomplete or contain dated information, and the scan quality may not be ideal. If we find a better copy in the future, we will add it to the Agilent website.

Support for Your Product

Agilent no longer sells or supports this product. You will find any other available product information on the Agilent Test & Measurement website:

www.tm.agilent.com

Search for the model number of this product, and the resulting product page will guide you to any available information. Our service centers may be able to perform calibration if no repair parts are needed, but no other support from Agilent is available.

HEWLETT-PACKARD

HP 75000 SERIES C

500 MHz Digitizing Oscilloscope HP E1426A

Service Manual

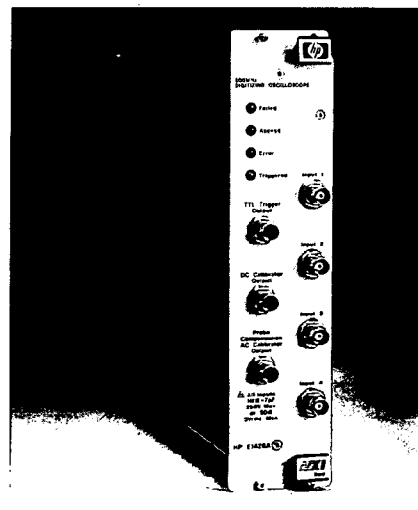



HP 75000 SERIES C

500 MHz Digitizing Oscilloscope HP E1426A

Service Manual

Enclosed is the Service Manual for the HP E1426A 500 MHz Digitizing Oscilloscope. Insert this manual into the binder that came with the HP E1426A User's Manual.



Copyright © Hewlett-Packard Company, 1991, 1999

Manual Part Number E1426-97003

Printed: January 1999
Printed in U.S.A.

HP 75000 SERIES C

500 MHz Digitizing Oscilloscope HP E1426A

Service Manual

Serial Numbers

Attached to the backplane connector of the instrument is a serial number plate. The serial number is in the form: 0000A00000. The first four digits and the letter are the serial number prefix. The last five digits are the suffix. The prefix is the same for identical instruments; it changes only when a configuration change is made to the instrument. The suffix, however, is assigned sequentially and is different for each instrument.

This manual applies directly to instruments with serial numbers prefixed 3028A and above.



Copyright © Hewlett-Packard Company, 1991, 1999

Manual Part Number E1426-97003

Printed: January 1999
Printed in U.S.A.

CERTIFICATION

Hewlett-Packard Company certifies that this product met its published specifications at the time of shipment from the factory. Hewlett-Packard further certifies that its calibration measurements are traceable to the United States National Institute of Standards and Technology (formerly National Bureau of Standards), to the extent allowed by that organization's calibration facility, and to the calibration facilities of other International Standards Organization members.

WARRANTY

This Hewlett-Packard product is warranted against defects in materials and workmanship for a period of three years from date of shipment. Duration and conditions of warranty for this product may be superseded when the product is integrated into (becomes a part of) other HP products. During the warranty period, Hewlett-Packard Company will, at its option, either repair or replace products which prove to be defective.

For warranty service or repair, this product must be returned to a service facility designated by Hewlett-Packard (HP). Buyer shall prepay shipping charges to HP and HP shall pay shipping charges to return the product to Buyer. However, Buyer shall pay all shipping charges, duties, and taxes for products returned to HP from another country.

HP warrants that its software and firmware designated by HP for use with a product will execute its programming instructions when properly installed on that product. HP does not warrant that the operation of the product, or software, or firmware will be uninterrupted or error free.

LIMITATION OF WARRANTY

The foregoing warranty shall not apply to defects resulting from improper or inadequate maintenance by Buyer, Buyer-supplied products or interfacing, unauthorized modification or misuse, operation outside of the environmental specifications for the product, or improper site preparation or maintenance.

The design and implementation of any circuit on this product is the sole responsibility of the Buyer. HP does not warrant the Buyer's circuitry or malfunctions of HP products that result from the Buyer's circuitry. In addition, HP does not warrant any damage that occurs as a result of the Buyer's circuit or any defects that result from Buyer-supplied products.

NO OTHER WARRANTY IS EXPRESSED OR IMPLIED. HP SPECIFICALLY DISCLAIMS THE IMPLIED WARRANTIES OF MERCHANTABILITY AND FITNESS FOR A PARTICULAR PURPOSE.

EXCLUSIVE REMEDIES

THE REMEDIES PROVIDED HEREIN ARE BUYER'S SOLE AND EXCLUSIVE REMEDIES. HP SHALL NOT BE LIABLE FOR ANY DIRECT, INDIRECT, SPECIAL, INCIDENTAL, OR CONSEQUENTIAL DAMAGES, WHETHER BASED ON CONTRACT, TORT, OR ANY OTHER LEGAL THEORY.

NOTICE

The information contained in this document is subject to change without notice. HEWLETT-PACKARD (HP) MAKES NO WARRANTY OF ANY KIND WITH REGARD TO THIS MATERIAL, INCLUDING, BUT NOT LIMITED TO, THE IMPLIED WARRANTIES OF MERCHANTABILITY AND FITNESS FOR A PARTICULAR PURPOSE. HP shall not be liable for errors contained herein or for incidental or consequential damages in connection with the furnishing, performance or use of this material. This document contains proprietary information which is protected by copyright. All rights are reserved. No part of this document may be photocopied, reproduced, or translated to another language without the prior written consent of Hewlett-Packard Company. HP assumes no responsibility for the use or reliability of its software on equipment that is not furnished by HP.

Restricted Rights Legend

Use, duplication, or disclosure by the Government is subject to restrictions as set forth in subdivision (b)(3)(ii) of the Rights in Technical Data and Computer Software clause at 52.227-7013. Hewlett-Packard Company, 3000 Hanover Street; Palo Alto, California 94304

Herstellerbescheinigung

Hiermit wird bescheinigt, dass dieses Gerät/System HP E1426A in Übereinstimmung mit den Bestimmungen von Postverfügung 1046/84 funktentstört ist. Der Deutschen Bundespost wurde das Inverkehrbringen dieses Gerätes/Systems angezeigt und die Berechtigung zur Überprüfung der Serie auf Einhaltung der Bestimmungen eingeräumt.

Zusatzinformation für Mess- und Testgeräte:
Werden Mess- und Testgeräte mit ungeschirmten Kabeln und/oder in offenen Messaufbauten verwendet, so ist vom Betreiber sicherzustellen, dass die Funk-Entstörbestimmungen unter Betriebsbedingungen an seiner Grundstücksgrenze eingehalten werden.

Manufacturer's Declaration

This is to certify that the equipment HP E1426A/E meets the radio frequency interference requirements of Directive FTZ 1046/84. The German Bundespost has been notified that this equipment was put into circulation and has been granted the right to check the product type for compliance with these requirements.

Additional Information for Test and Measurement Equipment:

If test and measurement equipment is operated with unshielded cables and/or used for measurements on open set-ups, the user has to assure that under operating conditions the Radio Interference Limits are still met at the border of the user's premises.

DECLARATION OF CONFORMITY

according to ISO/IEC Guide 22 and EN 45014

Manufacturer's Name: Hewlett-Packard Co.
Manufacturer's Address: Colorado Springs Division
1900 Garden of the Gods Rd.
Colorado Springs, CO 80907 USA

declares that the product

Product Name: Digitizing Oscilloscope Module
Model Number(s): HP E1426A
Product Option(s): All

conforms to the following Product Specifications:

Safety: IEC 1010-1:1990+A1 / EN 61010-1:1993
UL 3111
CSA-C22.2 No. 1010.1:1993

EMC: CISPR 11:1990 / EN 55011:1991 Group 1, Class A
IEC 801-2:1991 / EN 50082-1:1992 4 kV CD, 8 kV AD
IEC 801-3:1984 / EN 50082-1:1992 3 V/m, {1kHz 80% AM, 27-1000 MHz}
IEC 801-4:1988 / EN 50082-1:1992 0.5 kV Sig. Lines, 1 kV Power Lines

Supplementary Information:

The product herewith complies with the requirements of the Low Voltage Directive 73/23/EEC and the EMC Directive 89/336/EEC, and carries the CE-marking accordingly.

This product was tested in a typical configuration with Hewlett-Packard test systems.

Colorado Springs, 11/17/98



Ken Wyatt / Product Regulations Manager

European Contact: Your local Hewlett-Packard Sales and Service Office or Hewlett-Packard GmbH, Department ZQ / Standards
Europe, Herrenberger Strasse 130, D-71034 Boeblingen, Germany (FAX +49-7031-14-3143)

Printing History

The Printing History shown below lists all Editions and Updates of this manual and the printing date(s). The first printing of the manual is Edition 1. The Edition number increments by 1 whenever the manual is revised. Updates, which are issued between Editions, contain replacement pages to correct the current Edition of the manual. Updates are numbered sequentially starting with Update 1. When a new Edition is created, it contains all the Update information for the previous Edition. Each new Edition or Update also includes a revised copy of this printing history page. Many product updates or revisions do not require manual changes and, conversely, manual corrections may be done without accompanying product changes. Therefore, do not expect a one-to-one correspondence between product updates and manual updates.

Edition 1 (Part Number E1426-90902)	July 1990
Edition 1 (Part Number E1426-90902)	November 1990
Edition 1 (Part Number E1426-90902)	February 1991
Edition 1 (Part Number E1426-97003)	January 1999

Safety Summary

The following general safety precautions must be observed during all phases of operation, service, and repair of this product. Failure to comply with these precautions or with specific warnings elsewhere in this manual violates safety standards of design, manufacture, and intended use of the product. Hewlett-Packard Company assumes no liability for the customer's failure to comply with these requirements.

Ground the equipment: For Safety Class 1 equipment (equipment having a protective earth terminal), an uninterruptible safety earth ground must be provided from the mains power source to the product input wiring terminals or supplied power cable.

DO NOT operate the product in an explosive atmosphere or in the presence of flammable gases or fumes.

For continued protection against fire, replace the line fuse(s) only with fuse(s) of the same voltage and current rating and type. DO NOT use repaired fuses or short-circuited fuseholders.

Keep away from live circuits: Operating personnel must not remove equipment covers or shields. Procedures involving the removal of covers or shields are for use by service-trained personnel only. Under certain conditions, dangerous voltages may exist even with the equipment switched off. To avoid dangerous electrical shock, DO NOT perform procedures involving cover or shield removal unless you are qualified to do so.

DO NOT operate damaged equipment: Whenever it is possible that the safety protection features built into this product have been impaired, either through physical damage, excessive moisture, or any other reason, REMOVE POWER and do not use the product until safe operation can be verified by service-trained personnel. If necessary, return the product to a Hewlett-Packard Sales and Service Office for service and repair to ensure that safety features are maintained.

DO NOT service or adjust alone: Do not attempt internal service or adjustment unless another person, capable of rendering first aid and resuscitation, is present.

DO NOT substitute parts or modify equipment: Because of the danger of introducing additional hazards, do not install substitute parts or perform any unauthorized modification to the product. Return the product to a Hewlett-Packard Sales and Service Office for service and repair to ensure that safety features are maintained.

Safety Symbols

~ LINE

AC line voltage input receptacle.



Indicates hazardous voltages.



Instruction manual symbol affixed to product. Indicates that the user must refer to the manual for specific Warning or Caution information to avoid personal injury or damage to the product.



Affixed to product containing static sensitive devices – use antistatic handling procedures to prevent electrostatic discharge damage to components.

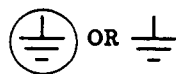

Indicates the field wiring terminal that must be connected to earth ground before operating the equipment – protects against electrical shock in case of fault.

NOTE

Calls attention to a procedure, practice, or condition that requires special attention by the reader

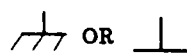

Frame or chassis ground terminal – typically connects to the equipment's metal frame.

WARNING

Calls attention to a procedure, practice, or condition that could cause bodily injury or death.



Alternating current (AC).

CAUTION

Calls attention to a procedure, practice, or condition that could possibly cause damage to equipment or permanent loss of data.



Direct current (DC).

HP 75000 Series C Documentation

Suggested Sequence for Using the Available Manuals

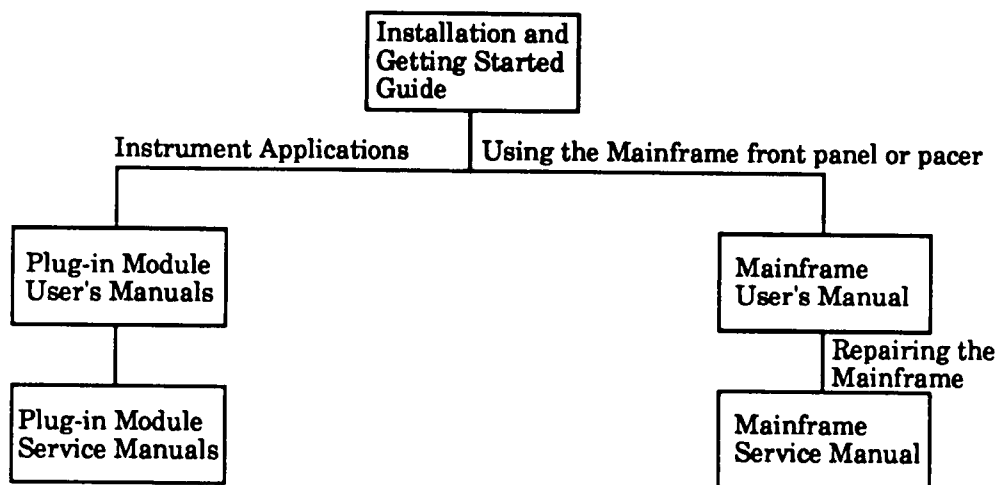

Manual Descriptions

Installation and Getting Started Guide. Contains step-by-step instructions for all aspects of plug-in module and mainframe installation. This guide also contains introductory programming information and examples.

HP E1405 Command Module User's Guide. Contains programming information for the Control Module, operation information (for the HP E1400B mainframe), and general programming information for instruments installed in the mainframe.

Plug-In Module User's Manuals. Contains plug-in module programming and configuration information. These manuals contain examples for the most-used module functions, and a complete SCPI command reference for the plug-in module.

HP E1400B Mainframe Service Manual. Contains service information for the mainframe. This manual contains information for ordering replaceable parts and exchanging assemblies. Also contains information and procedures for performance verification, adjustment, preventive maintenance, troubleshooting, and repair.

Plug-In Module Service Manuals. Contains plug-in module service information. These manuals contain information for exchanging the module or ordering replaceable parts. Dependent on the module, information and procedures for performance verification, adjustment, preventive maintenance, troubleshooting, and repair are also provided.

How to Use this Manual

Manual Overview

This manual shows how to service the HP E1426A 500 MHz Digitizing Oscilloscope. Oscilloscope operation, installation, and configuration information is not discussed in this manual. Refer to the "HP 75000 Series C HP E1426A User's Manual" for installation, configuration, and operating information.

Manual Content

This manual has eight chapters and one appendix.

- **Chapter 1 General Information:** provides a basic description, and lists available options and accessories. Also lists the tools and test equipment required for service.
- **Chapter 2 Installation:** contains information and procedures required to install the oscilloscope into the mainframe, perform initial inspection, prepare for use, and storing and shipping instructions.
- **Chapter 3 Operating Instructions:** contains information and procedures required to operate the oscilloscope, perform scheduled preventive maintenance, and perform the operator's check.
- **Chapter 4 Verification Tests:** contains information and procedures required to test the oscilloscope. Three levels are provided for functional verification, operation verification, and performance verification.
- **Chapter 5 Adjustments:** contains information and procedures required to readjust the oscilloscope to within its rated specifications.
- **Chapter 6 Replaceable Parts:** lists the part numbers for all user replaceable parts in the oscilloscope. Also provides information on ordering spare parts and module/assembly exchange.
- **Chapter 7 Manual Changes:** contains information required to adapt this manual to instruments whose serial numbers are lower than those listed on the title page.
- **Chapter 8 Service:** contains information and procedures to aid in fault isolation and repair of the oscilloscope.
- **Appendix A References:** contains a list of all reference documentation required when servicing the oscilloscope.

Contents

Chapter 1		Page
	GENERAL INFORMATION	1-1
1-1	Introduction	1-1
1-2	Specifications Considerations	1-1
1-3	Safety Considerations	1-1
1-4	Manual Updates	1-1
1-5	Description	1-1
1-6	Instruments Covered by This Manual	1-3
1-7	Options	1-3
1-8	Accessories Supplied	1-3
1-9	Equipment Available	1-3
1-10	Recommended Test Equipment	1-3
Chapter 2		Page
	INSTALLATION	2-1
2-1	Introduction.....	2-1
2-2	Initial Inspection	2-1
2-3	Preparation for Use	2-1
2-4	Operating Environment	2-2
2-5	Storage and Shipment	2-2
2-6	Environment	2-2
2-7	Packaging	2-2
Chapter 3		Page
	OPERATING INSTRUCTIONS	3-1
3-1	Introduction	3-1
3-2	Safety Considerations	3-1
3-3	Preventive Maintenance	3-2
3-4	Required Equipment	3-2
3-5	Cleaning Procedures	3-3
3-6	Operation	3-4
3-7	Operator's Checks	3-4

Chapter 4		Page
	VERIFICATION TESTS	4-1
4-1	Introduction	4-1
4-2	Equipment Required	4-1
4-3	Test Record	4-1
4-4	Calibration Cycle	4-1
4-5	Test Procedures	4-2
4-6	Functional Verification	4-2
4-7	Self-Test Procedure	4-2
4-8	Operation Verification	4-3
4-9	Performance Verification	4-3
4-10	DC Calibrator Test Procedure	4-4
4-11	Input Resistance Test Procedure	4-6
4-12	Voltage Measurement Accuracy Test Procedure	4-8
4-13	Offset Accuracy Test Procedure	4-11
4-14	Bandwidth Test Procedure	4-14
4-15	Time Measurement Accuracy Test Procedure	4-18
4-16	Trigger Sensitivity Test Procedure	4-21
4-17	Oscillator Output Test Procedure	4-24
Chapter 5		Page
	ADJUSTMENTS	5-1
5-1	Introduction	5-1
5-2	Equipment Required	5-1
5-3	Vertical Calibration Procedure	5-2
5-4	Delay Cal Calibration Procedure	5-4
5-5	Time Null Calibration Procedure	5-6
5-6	Logic Trigger Calibration Procedure	5-8
5-7	High Frequency Pulse Response Adjustment Procedure	5-10
Chapter 6		Page
	REPLACEABLE PARTS	6-1
6-1	Introduction	6-1
6-2	Ordering Information	6-1
6-3	Exchange Assemblies	6-1
6-4	Abbreviations	6-1
6-5	Replaceable Parts List	6-1
Chapter 7		Page
	MANUAL CHANGES	7-1
7-1	Introduction	7-1
Chapter 8		Page
	SERVICE	8-1
8-1	Introduction	8-1
8-2	Safety Considerations	8-1
8-3	Equipment Required	8-2
8-4	Troubleshooting	8-2
8-5	General	8-2
8-6	Service Aids	8-3
8-7	Visual Inspection	8-3
8-8	Troubleshooting Test	8-4
8-9	Repair and Replacement	8-6
8-10	Disassembly and Reassembly	8-6
8-11	Repair	8-10

Appendices		Page
A	References	A-1

LIST OF TABLES

No.	Title	Page
1-1.	Recommended Test Equipment	1-4
3-1.	Preventive Maintenance Equipment	3-2
4-1.	Verification Test Record	4-26
6-1.	Part Numbers for Exchange Assemblies	6-2
6-2.	Reference Designators and Abbreviations	6-3
6-3.	Replaceable Parts	6-5
6-4.	Code List of Manufacturers.....	6-8

LIST OF ILLUSTRATIONS

No.	Title	Page
1-1.	HP E1426A/E Accessories Supplied	1-0
1-2.	Oscilloscope Module Block Diagram	1-2
4-1.	DC Calibrator Test Set-up	4-4
4-2.	Input Resistance Test Set-up	4-6
4-3.	Voltage Measurement Accuracy Test Set-up	4-8
4-4.	Offset Accuracy Test Set-up	4-11
4-5.	Bandwidth Test Set-up	4-14
4-6.	Time Measurement Accuracy Test Set-up	4-18
4-7.	Trigger Sensitivity Test Set-up	4-21
4-8.	Oscillator Output Test Set-up	4-24
5-1.	Example: Vertical Calibration Setup	5-2
5-2.	Example: Delay Calibration Setup	5-4
5-3.	Example: Time Null Calibration Setup	5-6
5-4.	Example: Logic Trigger Calibration Setup	5-8
5-5.	High Frequency Pulse Response Adjustment Setup	5-11
6-1.	Oscilloscope Replaceable Parts	6-6
6-2.	A1 CPU PCA Replaceable Parts	6-7
6-3.	A2 Acquisition PCA Replaceable Parts	6-7

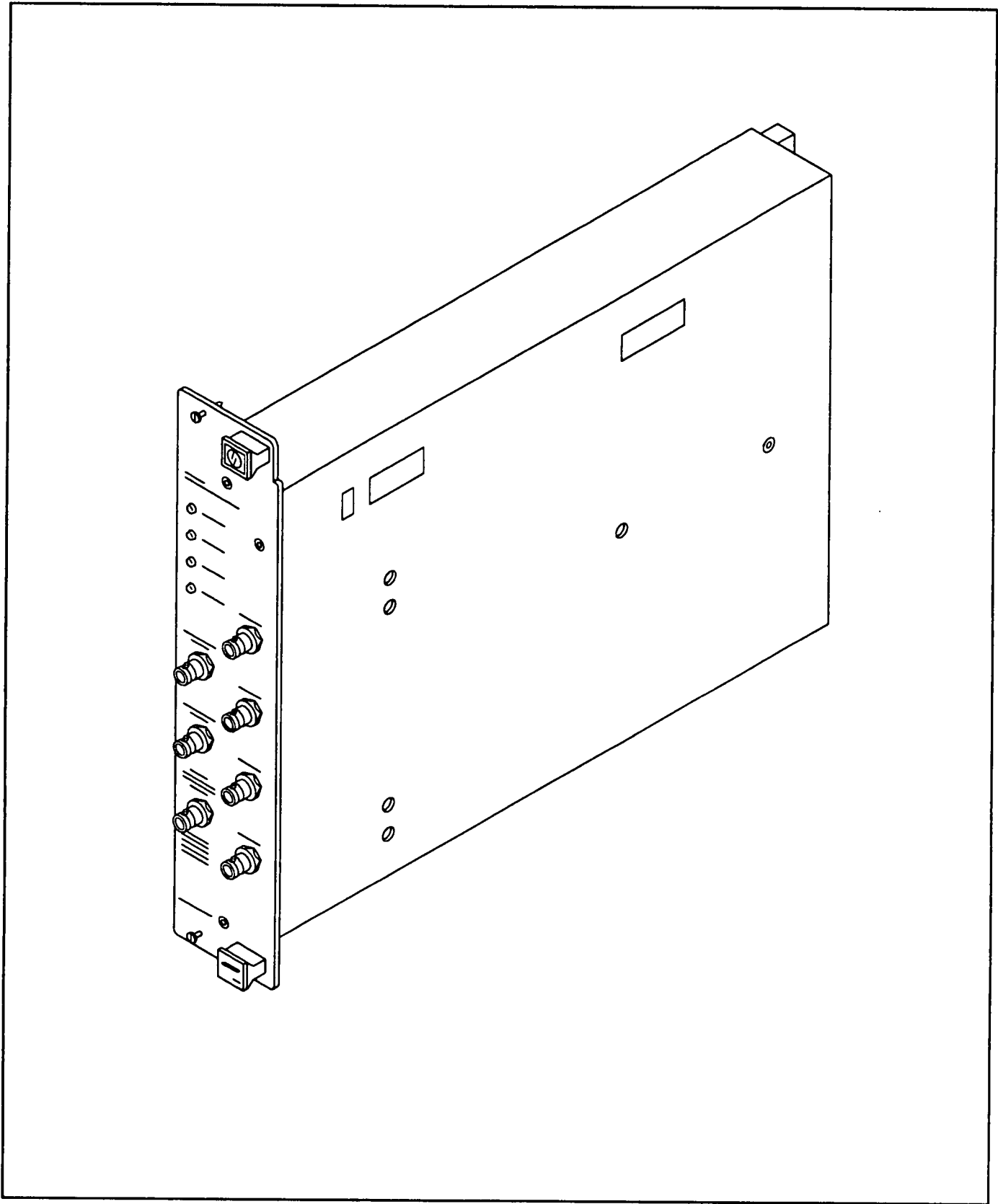

Figure 1-1. HP E1426A/E Accessories Supplied

General Information

1-1. Introduction

The HP E1426A Service Manual contains all the information required to test, adjust, troubleshoot, and repair the Hewlett-Packard Model E1426A C Size VXI 500 MHz Digitizing Oscilloscope. Figure 1-1 shows the HP E1426A Oscilloscope, along with all of the externally supplied accessories. Additional copies of the HP E1426A User's Manual and Service Manual can be ordered separately through your nearest Hewlett-Packard office.

1-2. Specifications Considerations

Instrument specifications are listed in Appendix A of the HP E1426A User's Manual. These specifications are the performance standards or limits against which the instrument may be tested.

1-3. Safety Considerations

This product is a Safety Class I instrument, that is, one provided with a protective earth terminal when installed in the mainframe. The mainframe, oscilloscope, and all related documentation should be reviewed for familiarization with safety markings and instructions before operation or service. Refer to the Safety Considerations page found at the beginning of this manual for a summary of the safety information. Safety information for preventive maintenance, testing, adjusting, or service is found in appropriate places throughout this manual.

1-4. Manual Updates

Manual Updates provide information necessary to update the manual. The Manual Update is identified by the manual print date and part number, both of which appear on the manual title page.

1-5. Description

The Oscilloscope module is a general purpose, four channel, 500 MHz (repetitive bandwidth) oscilloscope, which provides all the versatility and capability of digitizing oscilloscopes. The Oscilloscope module is a VXIbus C-Size message-based product, and can operate in a C-Size VXIbus mainframe using an HP E1405 Command Module.

The Oscilloscope module is comprised of a CPU Printed Circuit Assembly (PCA) (HP P/N E1426-69501) and an Acquisition PCA (HP P/N E1426-69502).

The Acquisition PCA attenuates/amplifies each of the four inputs. The conditioned input signal is then routed to a track and hold circuit. The signal is then multiplexed to an A/D Converter where it is changed into a digital word. This digital information is stored for use by the CPU PCA. A replica of the conditioned input signal is also used for triggering. Additional functions include:

- Time base circuit provides the timing signals necessary for data acquisition.
- AC calibrator circuit provides signals for probe compensation, trigger event, and calibration.
- DC calibrator circuit provides a calibration signal.

The CPU PCA contains the control and interface circuits necessary to direct oscilloscope operations. Control information (COMP or SCPI) is received from the mainframe controller, and the necessary instructions are sent to the Acquisition PCA to perform the specific task. When the digital waveform information is received from the Acquisition PCA, all the user requested parameters are measured and routed to the mainframe. Additional functions include:

- TTL and ECL trigger signals from the mainframe are routed to the Acquisition PCA to perform "external trigger" functions.
- TTL and ECL trigger signals from the oscilloscope are routed to the mainframe over the backplane trigger bus lines.
- Trigger circuit provides a TTL Trigger output signal on the front panel.

Refer to the HP E1426A User's Manual for additional information on the HP E1426A Oscilloscope.

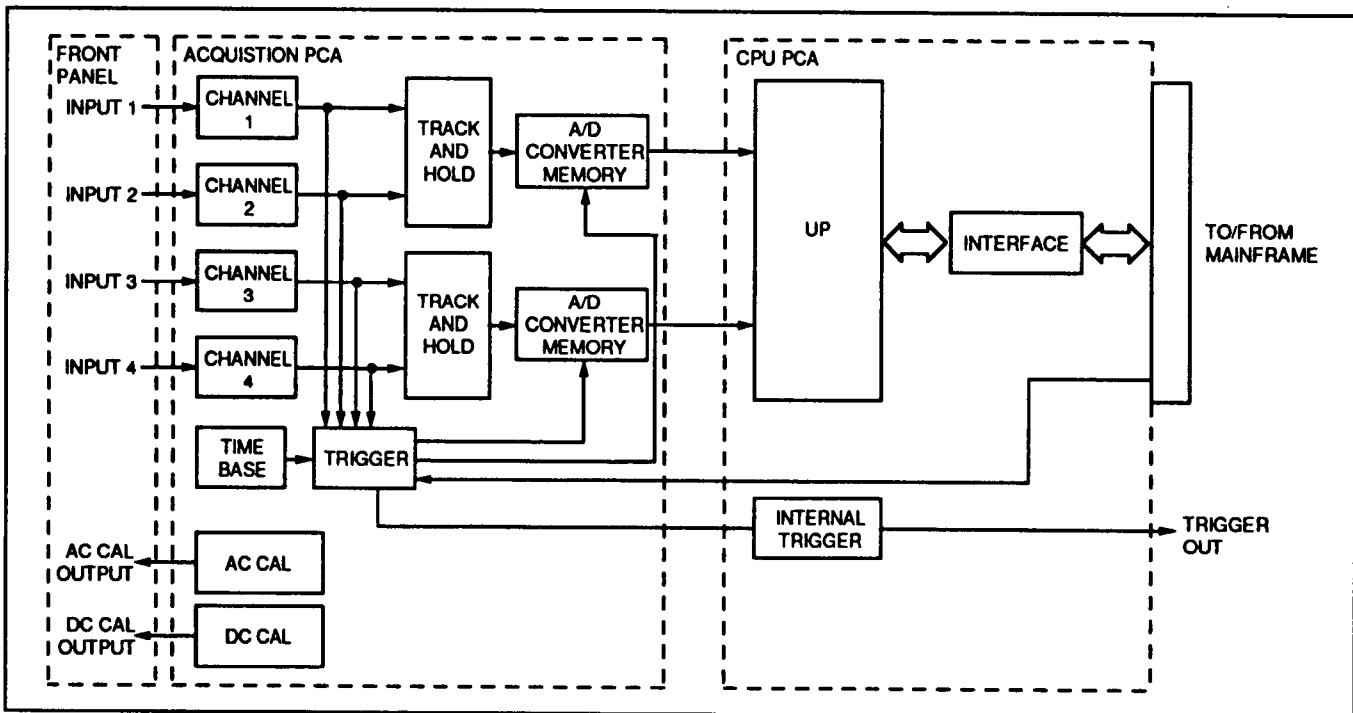

Figure 1-2. Oscilloscope Module Block Diagram

1-6. Instruments Covered by this Manual

Instruments covered by this manual are identified by a serial number prefix listed on the title page. Hewlett-Packard uses a two part serial number in the form XXXXAYYYYY, where XXXX is the serial prefix, A is the country of origin (A=USA) and YYYYY is the serial suffix. The serial number prefix identifies a series of identical instruments. The serial number suffix is assigned sequentially and is unique to each instrument. If the serial number prefix of your instrument is greater than the one listed on the title page, a yellow Manual Update supplement will explain how to adapt this manual to your instrument. If the serial number prefix of your instrument is lower than the one listed on the title page, information contained in Chapter 7 (Manual Changes) will explain how to adapt this manual to your instrument.

1-7. Options

There are no options currently available for the HP E1426A Oscilloscope Module.

1-8. Accessories Supplied

There are no accessories currently available for the HP E1426A Oscilloscope Module.

1-9. Equipment Available

A number of oscilloscope accessories are available for use with the HP E1426A Oscilloscope, and include:

- The HP 10400A Miniature Probe Family
- The HP 10002A 50:1 Voltage Divider Probe
- The HP 10020A Resistive Divider Probe Kit
- The HP 1124A Active Divider Probe Kit

For a complete list of oscilloscope accessories currently available, contact your nearest Hewlett-Packard sales office.

1-10. Recommended Test Equipment

Table 1-1 lists the test equipment recommended for testing, adjusting and servicing the oscilloscope. Essential requirements for each piece of test equipment are described in the Critical Specifications column. Other equipment can be substituted if it meets or exceeds the critical specifications.

Table 1-1. Recommended Test Equipment

Instrument	Critical Specifications	Recommended Model	Use*
Controller, HP-IB	HP-IB compatibility as defined by IEEE Standard 488-1978 and the identical ANSI Standard MC1.1: SH1, AH1, T2, TE0, L2, LE0, SR0, RL0, PP0, DC0, DT0, and C1, 2, 3, 4, 5.	HP Series 200/300	P,A,T
Mainframe	Compatible with the oscilloscope	HP E1400B	P,A,T
Slot 0 Command Module	VXI "C" size w/HPIB	HP E1405A	P,A,T
Digital Multimeter	5 1/2 digit resolution dc voltage accuracy 8 ppm/yr 4-wire resistance accuracy $\pm 0.25\%$	HP 3458A	P,T
Fast-rise Pulse Generator	Rise Time < 175ps (faster is better)	PPL 1110B driver (note) PPL 1107B head (note)	A
Oscilloscope	General-purpose	HP 54501A	T
Power Meter/Power Sensor	1-500 MHz, -70 dBm to 0 dBm, 3% accuracy	HP 436A/8482A	P
Power Splitter	50 Ω type N, outputs differ by <0.15 dB	HP 11667A	P
Power Supply	7 mV -35 V dc, 0.1 mV resolution	HP 6114A	P
Signal Generator	1-500 MHz sine wave amplitude 3-170 mVrms time base accuracy $\pm 0.001\%$	HP 8656B Opt 001	P
Cables and Adapters			
Adapter (2)	BNC to dual banana	HP 1251-2277	P
Adapter (3)	BNC tee (m)(f)(f)	HP 1250-0781	P,T
Adapter	BNC (f)(f)	HP 1250-0080	T
Adapter	N (m) to BNC (f)	HP 1250-0780	P
Adapter	N (m) to BNC (m)	HP 1250-0082	P
Adapter	Type N (f) to BNC (m)	HP 1250-0077	A
Adapter	Type N (f) to SMA (m)	HP 1250-1562	A
Cable (2)	BNC-3 foot	HP 10503A	P,T
Cable (4)	BNC-9 inch	HP 10502A	P,T
Cable	Type N-3 foot (m) (m)	HP 11500A or B	P
<p>Note PPL = Picosecond Pulse Labs * M = Preventative Maintenance, F = Functional Verification Check, C = Operational Verification Tests, P = Performance Verification Tests, A = Adjustments, T = Troubleshooting</p>			

2-1. Introduction

This chapter provides the information needed to install the HP E1426A Oscilloscope. Included is information pertinent to initial inspection, preparation for use, environment, storage and shipment.

2-2. Initial Inspection**Warning**

To avoid hazardous electrical shock, do not perform electrical tests when there are signs of shipping damage to any portion of the outer enclosure (covers, panels, etc).

Inspect the shipping container for damage. If the shipping container or cushioning material is damaged, it should be kept until the contents of the shipment have been checked for completeness and the instrument has been checked mechanically and electrically. The contents of the shipment should be as shown in Figure 1-1. Procedures for checking electrical performance are given in Chapter 4. If the contents are incomplete, if there is mechanical damage or defect, or if the instrument does not pass the electrical performance test, notify the nearest Hewlett-Packard office. If the shipping container is damaged or the cushioning material shows signs of stress, notify the carrier as well as the Hewlett-Packard office. Keep the shipping materials for the carrier's inspection.

2-3. Preparation for Use

Complete instructions for preparing the HP E1426A Oscilloscope for use are provided in the HP E1426A User's Manual, the HP E1400B Mainframe User's Manual, and the HP E1405 Command Module User's Manual. Procedures include:

HP E1426A User's Manual (Chapter 2)

- Logical Address Switch Selection
- Bus Request/Grant Level Switch Selection
- Servant Area Switch Selection
- Connecting User Inputs
- Mainframe Installation

HP E1405A Command Module User's Manual (or applicable command module manual)

- Interface Cable Connection
- Addressing the Plug-In Modules
- System Configuration

HP E1400B Mainframe User's Manual (or applicable mainframe manual)

- AC Power Selection and Connection
- Module Installation

2-4. Operating Environment

The operating environment should be within the following : limitations

Temperature 0 to +55°C

Humidity 65% relative (0 to +40°C)

2-5. Storage and Shipment

2-6. Environment

The instrument should be stored in a clean, dry environment. The following environmental limitations apply to both storage and shipment:

Temperature -40 to +75°C

Humidity <65% relative (0 to +40°C)

2-7. Packaging

Preparation for Packaging. Remove any adapters or connectors before packaging instrument for shipping.

Tagging for Service. If the instrument is being returned to Hewlett-Packard for service, please complete one of the blue repair tags located at the back of this manual and attach it to the instrument.

Original Packaging. Containers and materials identical to those used in factory packaging are available through Hewlett-Packard offices. Mark the container "FRAGILE" to assure careful handling. In any correspondence refer to the instrument by model number and full serial number.

Other Packaging. The following general instructions should be used for re-packaging with commercially available materials:

- a. Wrap the instrument in heavy paper or plastic. (If shipping to a Hewlett-Packard office or service center, complete one of the blue tags mentioned above and attach it to the instrument.)
- b. Use a strong shipping container. A double-wall carton made of 2.4 MPa (350 psi) test material is adequate.
- c. Use enough shock-absorbing material (75 to 100 mm layer; 3 to 4 inches) around all sides of the instrument to provide firm cushion and prevent movement in the container. Protect the front panel with cardboard.
- d. Seal the shipping container securely.
- e. Mark the shipping container "FRAGILE" to assure careful handling.

Operating Instructions

3-1. Introduction

This chapter provides operating information for the HP E1426A Oscilloscope. Included are detailed operator's preventive maintenance procedures, operating instructions, and operator's checks. Both preventive maintenance and the operator's checks should be performed on a regular scheduled basis to keep the oscilloscope in an operational condition, and also prevent more serious malfunctions from occurring.

3-2. Safety Considerations

This paragraph contains information, cautions, and warnings which must be followed for your protection and to avoid damage to the equipment when performing preventive maintenance.

Before applying power, verify that the mainframe (the oscilloscope is installed in) is set to match the available line voltage and the correct fuse is installed. An uninterruptible safety earth ground must be provided from the main power source to the product input wiring terminals, power cord, or supplied power cord set.

Warning

Any interruption of the protective (grounding) conductor (inside or outside the instrument) or disconnecting the protective earth terminal will cause a potential shock hazard that could result in personal injury. (Grounding one conductor of a two conductor outlet is not sufficient protection.) In addition, verify that a common ground exists between the unit under test and this instrument prior to energizing either unit.

Whenever it is likely that the protection has been impaired, the instrument must be made inoperative and be secured against any unintended operation.

If this instrument is to be energized via an autotransformer (for voltage reduction) make sure the common terminal is connected to neutral (that is, the grounded side of the mains supply).

Servicing instructions are for use by service-trained personnel only. To avoid dangerous electric shock, do not perform any servicing unless qualified to do so.

Maintenance described in the manual is performed with power supplied to the instrument while protective covers are removed. Energy available at many points may, if contacted, result in personal injury. Where maintenance can be performed without power applied, the power should be removed.

Capacitors inside the instrument may still be charged even if the instrument has been disconnected from its source of supply.

For continued protection against fire hazard, replace the line fuse(s) only with 250V fuse(s) of the same current rating and type (for example, normal blow, time delay, etc.). Do not use repaired fuses or short circuited fuseholders.

Caution

Static electricity is a major cause of component failure. To prevent damage to the electrical components in the Oscilloscope, observe anti-static techniques whenever working on the Oscilloscope.

3-3. Preventive Maintenance

Preventive maintenance for the Oscilloscope consists of periodically cleaning the Oscilloscope.

Note

Hewlett-Packard recommends a 12-month interval between cleaning the Oscilloscope. However, cleaning intervals are mostly dependent upon where the Oscilloscope is used. The Oscilloscope should be cleaned more often if it is used in a dusty or very humid area.

3-4. Required Equipment

Table 3-1 shows the necessary equipment to perform scheduled preventive maintenance.

Table 3-1. Preventive Maintenance Equipment

Description	Requirement
Soft-bristle brush	Removing dust from printed circuit card
Mild Soap Solution	Cleaning panel
Lint-free cloth	Cleaning panel

Warning

Before removing the Oscilloscope from the mainframe, make sure the mainframe is disconnected from the power source, to eliminate the possibility of electrical shock.

3-5. Cleaning Procedures

The following items should be cleaned at 12-month intervals and more often if located in very dusty or humid areas:

Caution

Do not use a vacuum cleaner to remove dust from the A1 CPU PCA or the A2 Acquisition PCA. These assemblies have static sensitive devices that can be damaged by a vacuum cleaner.

1. Remove the A1 CPU PCA and the A2 Acquisition PCA. See Chapter 8 for instructions.

Caution

The A1 CPU PCA and the A2 Acquisition PCA contain static sensitive devices that can be damaged when handling. Use static control devices (wrist straps, static mats, etc) when handling these assemblies.

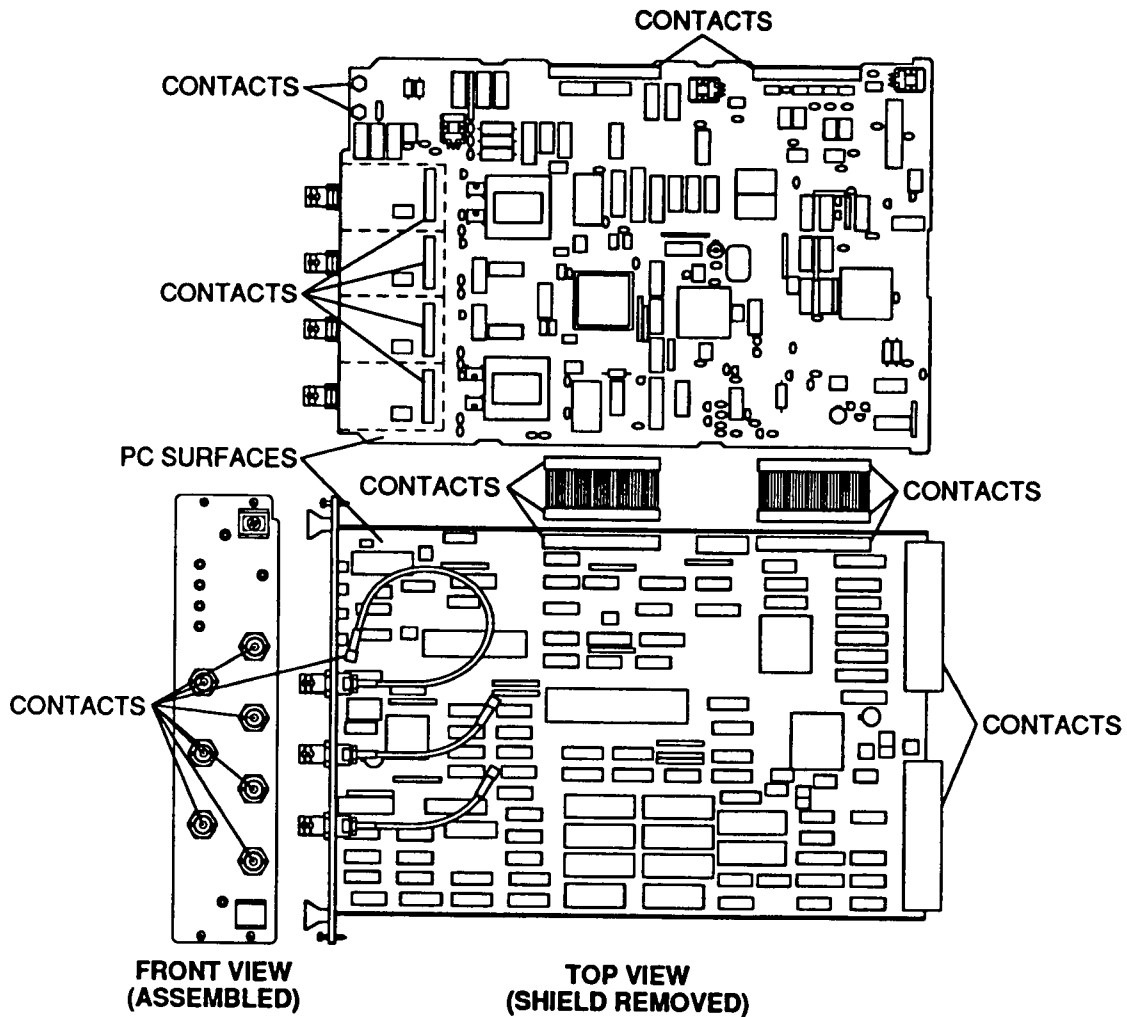

2. Using a soft-bristle brush only, remove dust from the printed circuit surface.
3. Clean the backplane connector contacts, the front panel BNC connectors, and any other contacts on both assemblies. Clean all interconnecting cable contacts.
4. Reassemble the A1 CPU PCA and the A2 Acquisition PCA. See Chapter 8 for instructions.
5. Clean the Oscilloscope panel and shield.

3-6. Operation

Complete instructions for operation of the Oscilloscope are provided in the HP E1426A User's Manual. Information includes:

- Getting Started
- Configuring the Oscilloscope
- Using the Oscilloscope with COMPAtible or SCPI
- Oscilloscope Command References in COMPAtible and SCPI
- Error Messages in COMPAtible and SCPI

3-7. Operator's Checks

The operator's checks should be performed after preventive maintenance (minimum), or any time to verify that the Oscilloscope is connected properly and is responding to the simplest commands.

Note

If necessary, refer to the HP E1405A Command Module User's Manual (or applicable command module manual) for information on address selection and external cabling guidelines.

Refer as required to the HP E1426A User's Manual for information on SCPI and COMPAtible commands.

1. Verify the Oscilloscope and Command Module are installed in the mainframe.
2. On the mainframe, connect a power cable and set the power to ON. Verify the mainframe/command module performs a proper power-up sequence.
 - If correct, proceed with step 3.
 - If incorrect, troubleshoot mainframe/command module before proceeding.
3. Perform clear status, reset, then preset the Oscilloscope.

4. Execute the Oscilloscope functional test using the **TEST:TALL** command.
5. Allow approximately 15 seconds for the test to complete, then read the test event register to verify that no errors were generated during the test.
 - If +0 is returned, then no failure was encountered.
 - If any number other than 0 is returned, then a failure was detected. See Chapter 8 for troubleshooting information.

Note

Test failures can be caused by improper cabling, or improper selection of the interface select code, primary address setting, and/or secondary address setting. Verify proper connection and address selection using the applicable command module and mainframe manuals before troubleshooting.

Example

For the example, use:

- an HP-IB select code of 7, primary address of 09, and secondary address of 05 for the Oscilloscope
- COMPAtible programming language
- an HP Series 200/300 Computer with HP BASIC

10	OUTPUT 70905;"*CLS"	<i>Clear status.</i>
20	OUTPUT 70905;"*RST"	<i>Resets the Oscilloscope to its default state.</i>
30	OUTPUT 70905;"SUMM:PRES"	<i>Presets the Oscilloscope.</i>
40	OUTPUT 70905;"TEST:TALL"	<i>Perform all test routines.</i>
50	OUTPUT 70905;"SUMM:QUES:TEST?"	<i>Read test event register.</i>
60	ENTER 70905;A	<i>Enter test event register results.</i>
70	PRINT A	<i>Print test event register results.</i>
80	OUTPUT 70905;"RUN"	<i>Restart the instrument.</i>
90	END	<i>Terminate program.</i>

Note

After a self-test is performed, the **RUN** command must be executed to restart the instrument.

Verification Tests

4-1. Introduction

Three levels of test procedures are provided in this chapter, and are used to verify that the HP E1426A Oscilloscope is:

- fully functional (Functional Verification),
- meeting critical specifications after a repair (Operation Verification), or
- meeting all published specifications (Performance Verification).

Note

To consider the tests valid, the following conditions must be met:

- The HP E1426A must have a 30 minute warm-up.
 - The line voltage must be 115/230 Vac $\pm 10\%$.
 - For greatest accuracy, the temperature of the test area should be between 18°C and 28°C and should be stable to within $\pm 1^\circ\text{C}$.
-

4-2. Equipment Required

Equipment required for the verification tests is listed in Table 1-1, Recommended Test Equipment. Any equipment that satisfies the critical specifications given in the table may be substituted.

4-3. Test Record

Results of the verification tests may be tabulated in Table 4-1, Verification Test Record. The Verification Test Record lists all of the verification test specifications and the acceptable limits for each specification. If verification test results are recorded during an incoming inspection of the instrument, they can be used for comparison during periodic maintenance or troubleshooting. The test results may also prove useful in verifying operation after repairs are made.

4-4. Calibration Cycle

This instrument requires periodic verification of performance to ensure that it is operating within specified tolerances. The performance verification tests described in this section should be performed at least once every six months or 1,000 hours; under conditions of heavy usage or severe operating environments, the tests should be more frequent. Annual cleaning procedures are detailed in Chapter 3, Preventive Maintenance.

4-5. Test Procedures

It is assumed that the person performing the verification tests understands how to operate the mainframe, HP E1426A, and specified test equipment. Equipment settings, other than those for the HP E1426A, are stated in general terms. For example, a test might require that a voltage of +5 Vdc be measured, however the Digital Multimeter instructions as to mode and range would not be specified and the operator would be expected to set that control and other controls as required to obtain a measurement. It is also assumed that the technician will select the cables, adapters, and probes required to complete the test setups illustrated in this section.

4-6. Functional Verification

The procedures in this section are used to quickly verify that the HP E1426A functions are working. These tests should be performed anytime the user wants to verify that the HP E1426A is connected properly and is responding to basic commands. All tests can be performed without accessing the interior of the instrument.

4-7. Self-Test Procedure

The purpose of this test is to verify the HP E1426A is communicating with the command module, external controller, and/or external terminal by performing a self-test.

Note

If necessary, refer to the HP E1405 Command Module User's Manual (or applicable command module manual) for information on address selection and external cabling guidelines.

Refer as required to the HP E1426A User's Manual for information on SCPI and COMPAtible commands.

1. Verify the HP E1426A and Command Module are installed in the mainframe.
2. On the mainframe, connect a power cable and set the power to ON. Verify the mainframe/command module performs a proper power-up sequence.
 - If correct, proceed with step 3.
 - If incorrect, troubleshoot mainframe/command module before proceeding.
3. Perform clear status, reset, then preset the HP E1426A.
4. Execute the test all routine using the **TEST:TALL** command.
5. Allow approximately 15 seconds for the test to complete, then read the test event register to verify that no errors were generated during the test.
 - If +0 is returned, then no failure was encountered.
 - If any number other than 0 is returned, then a failure was detected. See Chapter 8 for troubleshooting information.

Note

Test failures can be caused by improper cabling, or improper selection of the interface select code, primary address setting, and/or secondary address setting. Verify proper connection and address selection using the applicable command module and mainframe manuals before troubleshooting.

Example

For the example, use:

- an HP-IB select code of 7, primary address of 09, and secondary address of 05 for the HP E1426A
- COMPAtible programming language
- an HP Series 200/300 Computer with HP BASIC

10	OUTPUT 70905;"*CLS"	<i>Clear status.</i>
20	OUTPUT 70905;"*RST"	<i>Resets the HP E1426A to its default state.</i>
30	OUTPUT 70905;"SUMM:PRES"	<i>Presets the HP E1426A.</i>
40	OUTPUT 70905;"TEST:TALL"	<i>Perform test all routine.</i>
50	OUTPUT 70905;"SUMM:QUES:TEST?"	<i>Read test event register.</i>
60	ENTER 70905;A	<i>Enter test event register results.</i>
70	PRINT A	<i>Print test event register results.</i>
80	OUTPUT 70905;"RUN"	<i>Restart the instrument.</i>
90	END	<i>Terminate program.</i>

Note

After a test all is performed, the RUN command must be executed to restart the instrument.

4-8. Operation Verification

There are no operation verification procedures for the HP E1426A. Use the Performance verification test procedures for post repair check-out.

4-9. Performance Verification

The procedures in this section are used to test the HP E1426A Oscilloscope modules electrical performance using the specifications in Appendix A of the HP E1426A User's Manual as the performance standards. These tests are suitable for incoming inspection, troubleshooting, and preventive maintenance. All tests can be performed without accessing the interior of the instrument.

4-10. DC Calibrator Test Procedure

The DC CALIBRATOR output on the front panel is used for self-calibration and probe calibration. Though calibrator accuracy is not specified in the performance specifications, it must be within limits in order to provide accurate self-calibration.

1. Connect the equipment as shown below.

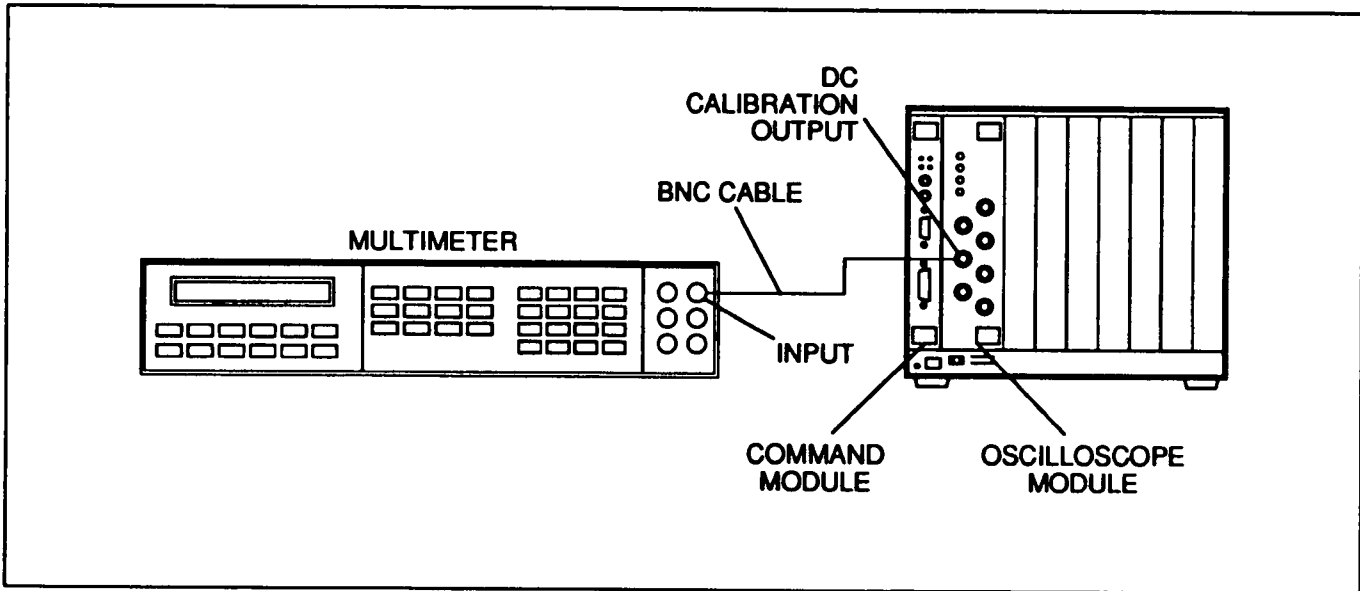

Figure 4-1. DC Calibrator Test Set-up

2. Set the HP E1426A controls as follows:

Reset HP E1426A *RST
 DC Calibrator Output to 0 V CAL:SCAL:DOUT ZVOL

3. Verify the Multimeter reads close to 0.000 V. Record the reading to four decimal places.

V1 = _____.

4. Set the HP E1426A Calibrator Output to 5 V (CAL:SCAL:DOUT FVOL).

5. Verify the Multimeter reads close to 5.000 V. Record the reading to four decimal places.

V2 = _____.

6. Subtract V1 from V2. The difference should be between 4.990 and 5.010 V.

Note

If the difference is not within the limits repair is necessary. See troubleshooting in Chapter 8.

7. Disconnect test equipment.

Example This program will automatically perform a DC Calibrator test. The program will pause to allow the user to get the reading from the multimeter.

The example is written using:

- an HP-IB select code of 7, primary address of 09, and secondary address of 05 for the HP E1426A
- COMPAtible programming language
- an HP Series 200/300 Computer with HP BASIC

Execute:

```
10 OUTPUT 70905;"*CLS"  
20 OUTPUT 70905;"*RST"  
30 OUTPUT 70905;"CAL:SCAL:DOUT ZVOL"  
40 PAUSE  
50 OUTPUT 70905;"CAL:SCAL:DOUT FVOL"  
60 PAUSE  
70 END
```

4-11. Input Resistance Test Procedure

This test checks the input resistance of the vertical inputs. A four-wire measurement is used for accuracy at 50 Ω .

1. Connect the equipment as shown below. Use the BNC-to-banana adapters to connect one of each BNC cable to the four-wire resistance connections on the multimeter, and connect the free ends of the cables to a BNC tee. Connect the male end of the BNC tee to the HP E1426A channel 1 input.

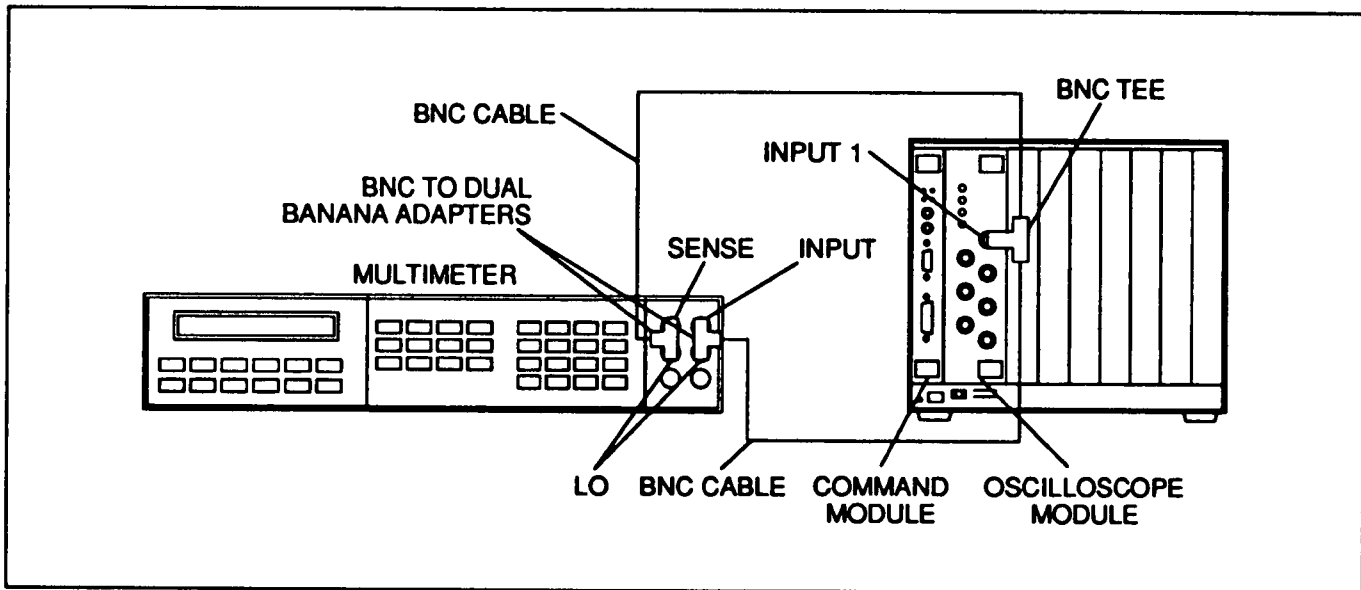

Figure 4-2. Input Resistance Test Set-up

2. Set the HP E1426A controls as follows:

Reset HP E1426A *RST
 Channel 1 DC at 1M Ω CHAN1:COUP DC

3. Verify the Multimeter reads 1M Ω \pm 10k Ω .
4. Set the HP E1426A channel 1 controls to 50 Ω (CHAN1:COUP DCF).
5. Verify the Multimeter reads 50 Ω \pm 0.5 Ω .
6. Repeat steps 1 through 5 for channels 2, 3, and 4.

Notes

When repeating the procedure, all references to channel 1 should be changed to the channel being tested.

Failure of this test indicates a faulty attenuator if resistance is out of specifications. One of the PCA's also may be at fault if input resistance cannot be changed. See troubleshooting in Chapter 8.

7. Disconnect test equipment.

Example This program will automatically prompt the user through the steps required to perform an input resistance test. The program will pause to allow the user to get the reading from the multimeter.

The example is written using:

- an HP-IB select code of 7, primary address of 09, and secondary address of 05 for the HP E1426A
- COMPAtible programming language
- an HP Series 200/300 Computer with HP BASIC

Execute:

```
10 OUTPUT 70905;"*CLS"
20 OUTPUT 70905;"*RST"
30 FOR Channel=1 TO 4
40     PRINT "Connect the multimeter to scope channel "&VAL$(Channel)
50     PRINT "1 MOhm"
60     OUTPUT 70905;"CHAN"&VAL$(Channel)&":COUP DC"
70     PAUSE
80     PRINT "50 Ohm"
90     OUTPUT 70905;"CHAN"&VAL$(Channel)&":COUP DCF"
100    PAUSE
110 NEXT Channel
120 OUTPUT 70905;"*RST"
130 END
```

4-12. Voltage Measurement Accuracy Test Procedure

This test verifies the voltage measurement accuracy of the instrument. A dual cursor measurement is made so offset errors are not a factor.

1. Connect the equipment as shown below. Use a banana-to-BNC adapter to connect the BNC cable to the power supply. Monitor the supply with the Multimeter. Set the power supply for 0 V output.

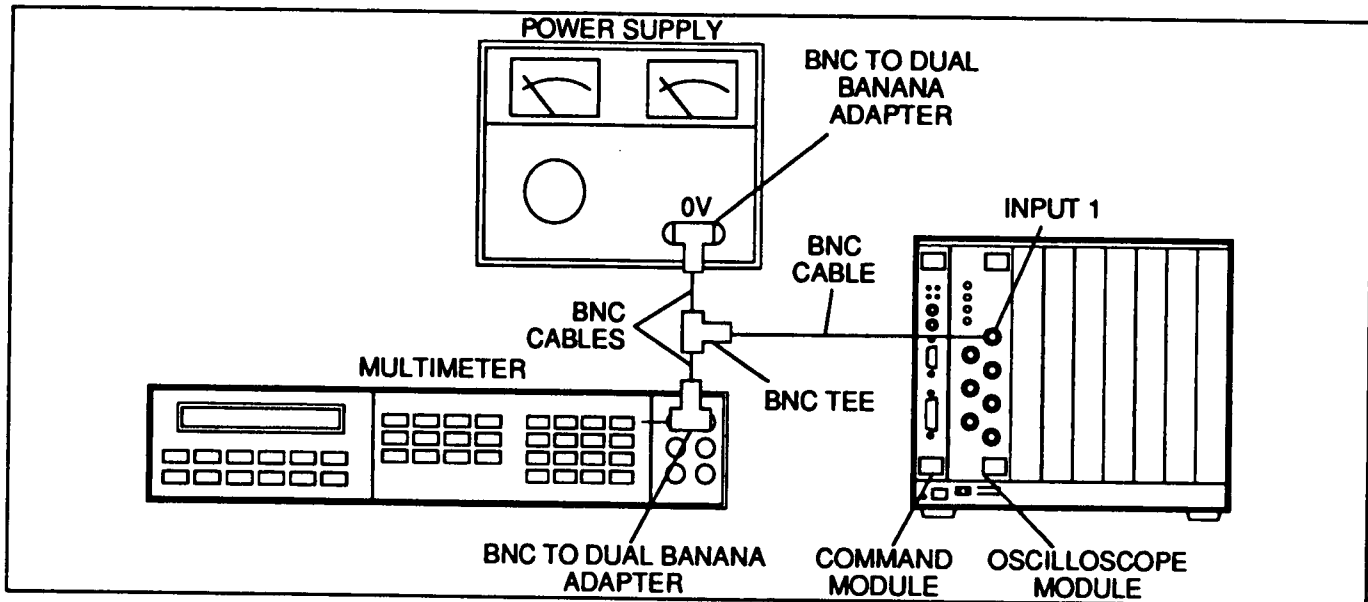

Figure 4-3. Voltage Measurement Accuracy Test Set-up

2. Set the HP E1426A controls as follows:

```

Reset HP E1426A ..... *RST
Time base to automatic ..... TIM:MOD AUT
Start data acquisition ..... RUN
Turn on channel 1 ..... VIEW CHAN1
Turn off unused channels ..... BLAN CHAN2,CHAN3,CHAN4
Channel 1 to DC at 1MΩ ..... CHAN1:COUP DC
Acquisition type to average ..... ACQ:TYP AVER
Acquisition count to 32 ..... ACQ:COUN 32
Channel 1 range to 40 V ..... CHAN1:RANG 40
Channel 1 offset to 17.5 V ..... CHAN1:OFFS 17.5
Measure channel 1 ..... MEAS:SOUR CHAN1
Digitize channel 1 ..... DIG CHAN1
Measure average voltage ..... MEAS:VAV?
  
```

3. Verify that average voltage as measured by the HP E1426A is close to 0 volts. Record the reading.

V1 = _____.

4. Set the power supply to output 35 Vdc. Repeat steps 2 and 3. Record the reading.

V2 = _____.

5. Subtract V1 from V2. The difference should be between 34.5 V and 35.5 V.

6. Repeat steps 2 through 5 for all the HP E1426A RANGE and OFFSet values, and power supply voltages specified in the table below.

RANGE	OFFSet	Power Supply	Tolerance	Limits
40 V	17.50000 V	35.00 V	±0.5 V	34.5 V to 35.5 V
16 V	7.00000 V	14.00 V	±0.2 V	13.8 V to 14.2 V
8 V	3.50000 V	7.000 V	±0.1 V	6.9 V to 7.1 V
4 V	1.75000 V	3.500 V	±0.05 V	3.45 V to 4.05 V
1.6 V	700.000 mV	1.400 V	±0.02 V	1.38 V to 1.42 V
800 mV	350.000 mV	700.0 mV	±10 mV	690 mV to 710 mV
400 mV	175.000 mV	350.0 mV	±5 mV	345 mV to 355 mV
160 mV	70.000 mV	140.0 mV	±2 mV	138 mV to 142 mV
80 mV	35.000 mV	70.0 mV	±1 mV	69 mV to 71 mV
40 mV*	17.500 mV	35.0 mV	±0.7 mV	34.3 mV to 35.7 mV
16 mV*	7.000 mV	14.0 mV	±0.7 mV	13.3 to 14.7 mV
8 mV*	3.500 mV	7.0 mV	±0.7 mV	6.3 mV to 7.7 mV

*For 40 mV to 8 mV ranges, it is necessary to disconnect the multimeter after verifying the output of the supply to avoid coupling noise into the channel.

7. Repeat steps 2 through 6 for channels 2, 3, and 4.

Notes

When repeating the procedure, all references to channel 1 should be changed to the channel being tested. Turn off all unused channels using the BLANK command.

Voltage measurement errors can be caused by the need for self calibration. Perform vertical calibration, (see Adjustment procedures, Chapter 5) before troubleshooting instrument. If self-calibration fails to correct problem, the cause may be the attenuator or A2 PCA. See troubleshooting in Chapter 8.

8. Disconnect test equipment.

Example This program will automatically prompt the user through the steps required to perform a voltage accuracy test, and print out the results of each measurement. The data at the end of the program corresponds to the values for range, offset and supply voltage in each measurement.

The example is written using:

- an HP-IB select code of 7, primary address of 09, and secondary address of 05 for the HP E1426A
- COMPatible programming language
- an HP Series 200/300 Computer with HP BASIC

Execute:

```

10  OPTION BASE 1
20  DIM Range(12),Offset(12),Power_supply(12),Zero_offset(12)
30  RESTORE
40  READ Range(*),Offset(*),Power_supply(*)
50  OUTPUT 70905;"*CLS"
60  OUTPUT 70905;"*RST"
70  FOR Channel=1 TO 4
80      OUTPUT 70905;"TIM:MOD AUT"
90      OUTPUT 70905;"RUN"
100     OUTPUT 70905;"BLAN CHAN1,CHAN2,CHAN3,CHAN4"
110     OUTPUT 70905;"VIEW CHAN"&VAL$(Channel)
120     OUTPUT 70905;"CHAN"&VAL$(Channel)&":COUP DC"
130     OUTPUT 70905;"ACQ:TYP AVER"
140     OUTPUT 70905;"ACQ:COUN 32"
150     PRINT "Connect the power supply to scope channel "&VAL$(Channel)
160     FOR Measurement=1 TO 12
170         PRINT "Set the power supply to 0 volts"
180         PAUSE
190         OUTPUT 70905;"CHAN"&VAL$(Channel)&":RANG "&VAL$(Range(Measurement))
200         OUTPUT 70905;"CHAN"&VAL$(Channel)&":OFFS "&VAL$(Offset(Measurement))
210         OUTPUT 70905;"MEAS:SOUR CHAN"&VAL$(Channel)
220         OUTPUT 70905;"DIG CHAN"&VAL$(Channel)
230         OUTPUT 70905;"MEAS:VAV?"
240         ENTER 70905;Zero_val
250         PRINT "Set the power supply to "&VAL$(Power_supply(Measurement))&" volts"
260         PAUSE
270         OUTPUT 70905;"DIG CHAN"&VAL$(Channel)
280         OUTPUT 70905;"MEAS:VAV?"
290         ENTER 70905;Voltage_val
300         Result=Voltage_val-Zero_val
310         PRINT "Result = "&VAL$(Result)
320     NEXT Measurement
330 NEXT Channel
340 OUTPUT 70905;"*RST"
350 !Range values for each measurement
360 DATA 40,16,8,4,1.6,800E-3,400E-3,160E-3,80E-3,40E-3,16E-3,8E-3
370 !Offset values for each measurement
380 DATA 17.5,7,3.5,1.75,700E-3,350E-3,175E-3,70E-3,35E-3,17.5E-3,7E-3,3.5E-3
390 !Power supply values for each measurement
400 DATA 35,14,7,3.5,1.4,700E-3,350E-3,140E-3,70E-3,35E-3,14E-3,7E-3
410 END

```

4-13. Offset Accuracy Test Procedure

This test verifies offset accuracy.

1. Connect the equipment as shown below. Use a banana-to-BNC adapter to connect the BNC cable to the power supply. Set the power Supply for 20 V output.

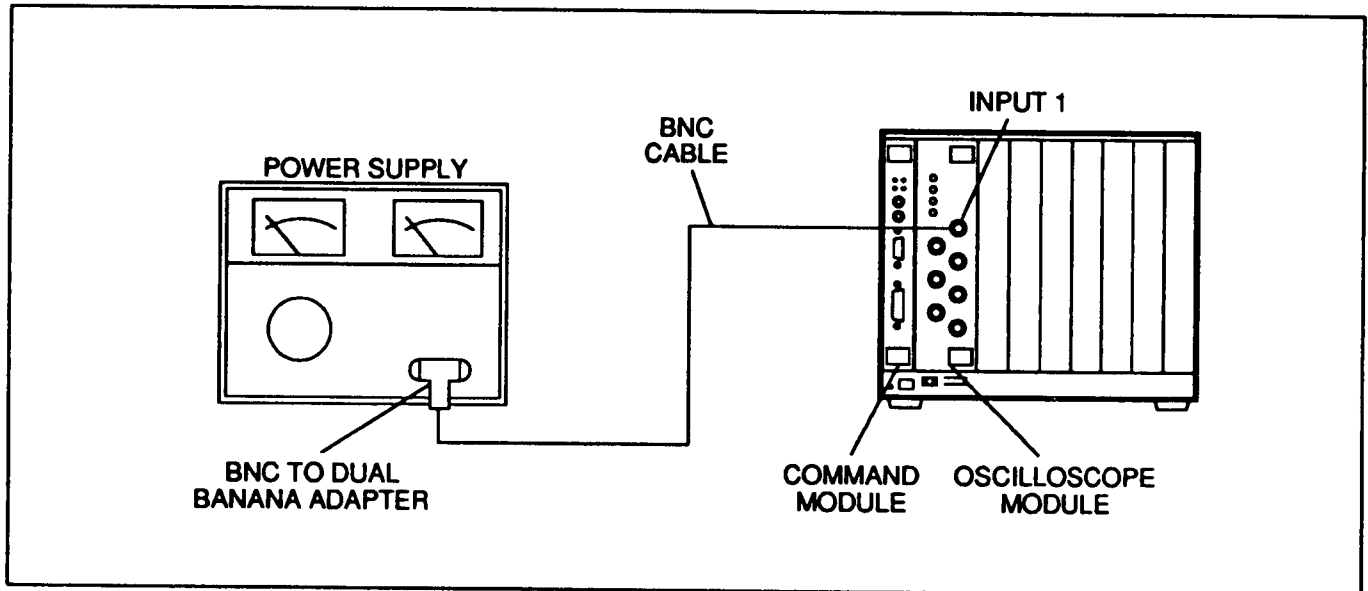

Figure 4-4. Offset Accuracy Test Set-up

2. Set the HP E1426A controls as follows:

```

Reset HP E1426A ..... *RST
Time base to automatic ..... TIM:MOD AUT
Start data acquisition ..... RUN
Turn on channel 1 ..... VIEW CHAN1
Turn off unused channels ..... BLAN CHAN2,CHAN3,CHAN4
Channel 1 to DC at 1MΩ ..... CHAN1:COUP DC
Acquisition type to average ..... ACQ:TYP AVER
Acquisition count to 32 ..... ACQ:COUN 32
Channel 1 range to 4 V ..... CHAN1:RANG 4
Channel 1 offset to 20 V ..... CHAN1:OFFS 20
Measure channel 1 ..... MEAS:SOUR CHAN1
Digitize channel 1 ..... DIG CHAN1
Measure average voltage ..... MEAS:VAV?
    
```

3. Verify that average voltage as measured by the HP E1426A is between 19.820 V and 20.180 V.
4. Repeat steps 2 and 3 for all the HP E1426A RANGE and OFFSet values, and power supply voltages specified in the table below.

RANGe	OFFSet	Power Supply	Tolerance	Limits
4 V	20.0000 V	20.000 V	±180 mV	19.820 V to 20.180 V
1.6 V	9.00000 V	9.000 V	±77 mV	8.923 V to 9.077 V
800 mV	5.00000 V	5.000 V	±41 mV	4.959 V to 5.041 V

5. Repeat steps 2 through 4 for channels 2, 3, and 4.

Notes

When repeating the procedure, all references to channel 1 should be changed to the channel being tested. Turn off all unused channels using the BLANK command.

Offset errors can be caused by the need for self calibration. Perform vertical calibration, (see Adjustment procedures, Chapter 5) before troubleshooting instrument. If self-calibration fails to correct problem, cause may be the attenuator or A2 PCA. See troubleshooting in Chapter 8.

6. Disconnect test equipment.

Example This program will automatically prompt the user through the steps required to perform an offset accuracy test, and print out the results of each measurement. The data at the end of the program corresponds to the values for range, offset and supply voltage in each measurement.

The example is written using:

- an HP-IB select code of 7, primary address of 09, and secondary address of 05 for the HP E1426A
- COMPAtible programming language
- an HP Series 200/300 Computer with HP BASIC

Execute:

```

10  OPTION BASE 1
20  DIM Range(3),Offset(3),Power_supply(3)
30  RESTORE
40  READ Range(*),Offset(*),Power_supply(*)
50  OUTPUT 70905;"*CLS"
60  OUTPUT 70905;"*RST"
70  FOR Channel=1 TO 4
80      OUTPUT 70905;"TIM:MOD AUT"
90      OUTPUT 70905;"RUN"
100     OUTPUT 70905;"BLAN CHAN1,CHAN2,CHAN3,CHAN4"
110     OUTPUT 70905;"VIEW CHAN"&VAL$(Channel)
120     OUTPUT 70905;"CHAN"&VAL$(Channel)&":COUP DC"
130     OUTPUT 70905;"ACQ:TYP AVER"
140     OUTPUT 70905;"ACQ:COUN 32"
150     PRINT "Connect the power supply to scope channel "&VAL$(Channel)
160     FOR Measurement=1 TO 3
170         PRINT "Set the power supply to "&VAL$(Power_supply(Measurement))&" volts"
180         PAUSE
190         OUTPUT 70905;"CHAN"&VAL$(Channel)&":RANG "&VAL$(Range(Measurement))
200         OUTPUT 70905;"CHAN"&VAL$(Channel)&":OFFS "&VAL$(Offset(Measurement))
210         OUTPUT 70905;"MEAS:SOUR CHAN"&VAL$(Channel)
220         OUTPUT 70905;"DIG CHAN"&VAL$(Channel)
230         OUTPUT 70905;"MEAS:VAV?"
240         ENTER 70905;Voltage_val
250         PRINT "Result = "&VAL$(Voltage_val)
260     NEXT Measurement
270 NEXT Channel
280 OUTPUT 70905;"*RST"
290 DATA 4,1.6,800E-3                !Range values for each measurement
300 DATA 20,9,5                    !Offset values for each measurement
310 DATA 20,9,5                    !Power supply values for each measurement
320 END

```

4-14. Bandwidth Test Procedure

This test checks the repetitive and real time bandwidths of the HP E1426A.

1. Connect the equipment as shown below. Use a type N cable to connect the signal generator to the power splitter input. Connect the power sensor to one output of the power splitter. Use an N-to-BNC adapter to connect the other power splitter output to the HP E1426A channel 1 input.

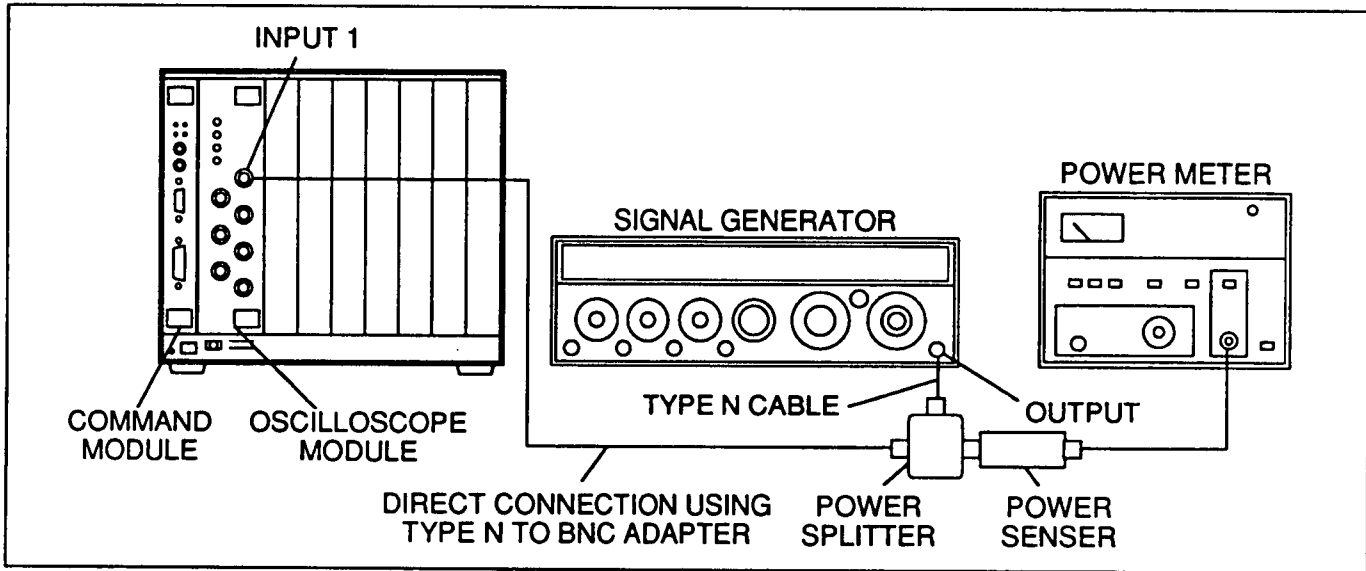

Figure 4-5. Bandwidth Test Set-up

Bandwidth ≥ 80 mV

2. Set the Signal Generator controls as follows:

Frequency 1 MHz
Output -2.4 dBm

Note

Setting the output to -2.4 dBm will produce a -8.4 dBm level at the HP 1426A 50 Ω input (loss occurs through the power splitter).

3. Set the HP E1426A controls as follows:

Reset HP E1426A *RST
Time base to 2 μ sec TIM:RANG 2E-6
Turn on channel 1 VIEW CHAN1
Turn off unused channels BLAN CHAN2,CHAN3,CHAN4
Channel 1 to DC at 50 Ω CHAN1:COUP DCF
Trigger source to channel 1 TRIG:SOUR CHAN1
Acquisition type to average ACQ:TYP AVER
Acquisition count to 32 ACQ:COUN 32
Channel 1 range to 40 mV CHAN1:RANG 3.2E-1
Measure channel 1 MEAS:SOUR CHAN1
Digitize channel 1 DIG CHAN1
Measure peak-to-peak voltage MEAS:VPP?

4. Record the measured peak-to-peak voltage.

V 1 MHz = _____.

5. Set the Power Meter controls as follows:

Calibration Factor to power sensor 1 MHz value
Press dB REF to set a 0 dB reference
Calibration Factor to power sensor 500 MHz value

6. Set the Signal Generator frequency to 500 MHz, then adjust the output level for a power meter reading as close as possible to 0.0 dB (REL). Record the reading.

Power Meter = _____.

7. Set the HP E1426A controls as follows:

Time base to 5 nsec..... TIM:RANG 5E-9
Digitize channel 1 DIG CHAN1
Measure peak-to-peak voltage MEAS:VPP?

8. Record the measured peak-to-peak voltage.

V 500 MHz = _____.

9. Calculate the response from the measured results in steps 4 and 8 using the following formula:

$$\text{response(dB)} = 20 \log_{10} \frac{V_{500\text{MHz}}}{V_{1\text{MHz}}} = 20 \log_{10} \frac{\quad}{\quad} = \quad \text{dB}$$

10. Correct the result in step 9 with any difference in the power meter reading from step 6 using the following formula. Observe signs.

$$(\text{_____ step 9}) - (\text{_____ step 6}) = \quad \text{dB}$$

For example:

Result from step 9 = -2.3 dB

Power meter reading = -0.2 dB(REL)

then true response = (-2.3)-(-0.2) = -2.1 dB

11. Verify the result in step 10 is ≤ -3.0 dB.

12. Connect the power splitter to next channel being tested. Repeat steps 2 through 12 for channels 2, 3, and 4.

Note

When repeating the procedure, all references to channel 1 should be changed to the channel being tested. Turn off all unused channels using the BLANK command.

Bandwidth <80 mV

13. Connect the power splitter to channel 1.

14. Set the Signal Generator controls as follows:

Frequency 1 MHz
Output -20.6 dBm

Note

Setting the output to -20.6 dBm will produce a -26.6 dBm level at the HP 1426A 50Ω input (loss occurs through the power splitter).

15. Set the HP E1426A controls as follows:

Reset HP E1426A *RST
 Time base to 2μsec TIM:RANG 2E-6
 Turn on channel 1 VIEW CHAN1
 Turn off unused channels BLAN CHAN2,CHAN3,CHAN4
 Channel 1 to DC at 50Ω CHAN1:COUP DCF
 Trigger source to channel 1 TRIG:SOUR CHAN1
 Acquisition type to average ACQ:TYP AVER
 Acquisition count to 32 ACQ:COUN 32
 Channel 1 range to 40 mV CHAN1:RANG 4E-2
 Measure channel 1 MEAS:SOUR CHAN1
 Digitize channel 1 DIG CHAN1
 Measure peak-to-peak voltage MEAS:VPP?

16. Record the measured peak-to-peak voltage.

V 1 MHz = _____.

17. Set the Power Meter controls as follows:

Calibration Factor to power sensor 1 MHz value
 Press dB REF to set a 0 dB reference
 Calibration Factor to power sensor 500 MHz value

18. Set the Signal Generator frequency to 500 MHz, then adjust the output level for a power meter reading as close as possible to 0.0 dB (REL). Record the reading.

Power Meter = _____.

19. Set the HP E1426A controls as follows:

Time base to 5 nsec..... TIM:RANG 5E-9
 Digitize channel 1 DIG CHAN1
 Measure peak-to-peak voltage MEAS:VPP?

20. Record the measured peak-to-peak voltage.

V 500 MHz = _____.

21. Calculate the response from the measured results in steps 16 and 20 using the following formula:

$$\text{response(dB)} = 20 \log_{10} \frac{V_{500\text{MHz}}}{V_{1\text{MHz}}} = 20 \log_{10} \frac{\quad}{\quad} = \quad \text{dB}$$

22. Correct the result from step 21 with any difference in the power meter reading from step 18 using the following formula. Observe signs.

$$(\quad \text{step 21}) - (\quad \text{step 18}) = \quad \text{dB}$$

23. Verify the result in step 22 is ≤ -3.5 dB.

24. Connect the power splitter to next channel being tested. Repeat steps 14 through 24 for channels 2, 3, and 4.

25. Disconnect test equipment.

Notes

When repeating the procedure, all references to channel 1 should be changed to the channel being tested. Turn off all unused channels using the BLANK command.

Bandwidth errors can be caused by the need for adjustment. Perform high frequency pulse response adjustment, (see Adjustment procedures, Chapter 5) before troubleshooting instrument. If adjustment fails to correct problem, cause may be the attenuator or A2 PCA. See troubleshooting in Chapter 8.

Example

This program is provided to show how to perform a bandwidth test, and print out the results of each measurement. The program pauses to allow the user to adjust the signal generator and power meter.

The example is written using:

- an HP-IB select code of 7, primary address of 09, and secondary address of 05 for the HP E1426A
- COMPAtible programming language
- an HP Series 200/300 Computer with HP BASIC

Execute:

```
10  OUTPUT 70905;"*CLS"
20  OUTPUT 70905;"*RST"
30  OUTPUT 70905;"TIM:RANG 2E-6"
40  OUTPUT 70905;"VIEW CHAN1"
50  OUTPUT 70905;"BLAN CHAN2,CHAN3,CHAN4"
60  OUTPUT 70905;"CHAN1:COUP DCF"
70  OUTPUT 70905;"TRIG:SOUR CHAN1"
80  OUTPUT 70905;"ACQ:TYP AVER"
90  OUTPUT 70905;"ACQ:COUN 32"
100 OUTPUT 70905;"CHAN1:RANG 3.2E-1"
110 OUTPUT 70905;"MEAS:SOUR CHAN1"
120 OUTPUT 70905;"DIG CHAN1"
130 OUTPUT 70905;"MEAS:VPP?"
140 ENTER 70905;A
150 PRINT A
160 PAUSE                                ! To adjust signal generator and power meter.
170 OUTPUT 70905;"TIM:RANG 5E-9"
180 OUTPUT 70905;"MEAS:SOUR CHAN1"
190 OUTPUT 70905;"DIG CHAN1"
200 OUTPUT 70905;"MEAS:VPP?"
210 ENTER 70905;B
220 PRINT B
230 PAUSE                                ! To calculate response and change test set up.
    .
    .                                ! Repeat for channels 2-4 .
    .
    .                                ! Repeat for <80 mV range.
    .
500 END
```

4-15. Time Measurement Accuracy Test Procedure

This test uses a precise frequency source to check the accuracy of time measurement functions.

1. Connect the equipment as shown below. Use an N-to-BNC adapter and BNC cable to connect the signal generator output to the HP E1426A channel 1 input.

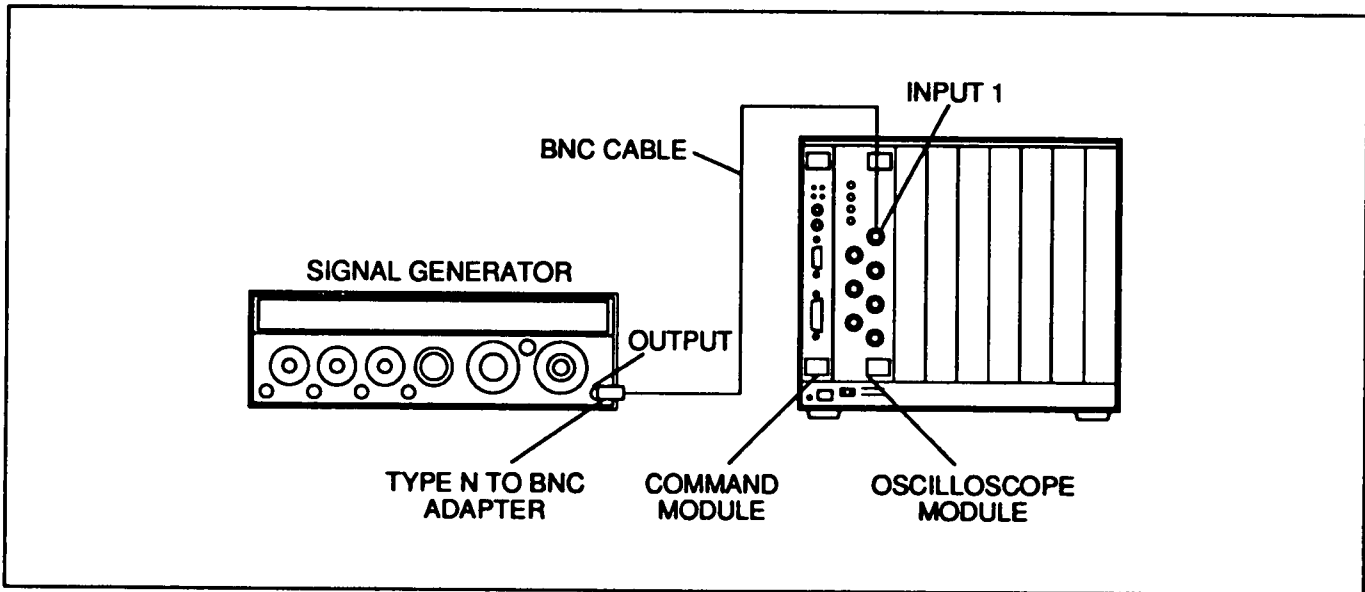

Figure 4-6. Time Measurement Accuracy Test Set-up

2. Set the Signal Generator controls as follows:

Frequency 500 MHz
Output 150 mVrms

3. Set the HP E1426A controls as follows:

Reset HP E1426A *RST
Time base to 5 nsec TIM:RANG 5E-9
Time base delay to 0 sec TIM:DEL 0
Turn on channel 1 VIEW CHAN1
Turn off unused channels BLAN CHAN2,CHAN3,CHAN4
Channel 1 to DC at 50Ω CHAN1:COUP DCF
Acquisition type to average ACQ:TYP AVER
Acquisition count to 8 ACQ:COUN 8
Channel 1 range to 400 mV CHAN1:RANG .4
Measure channel 1 MEAS:SOUR CHAN1
Digitize channel 1 DIG CHAN1
Measure time of 1st positive edge at 0 V MEAS:TVOL? 0,+1?

4. Record the measured time that 1st positive edge occurred at 0 V.

T1 = _____.

5. Set the HP E1426A controls as follows:

Time base delay to 8 nsec TIM:DEL 8E-9
 Measure channel 1 MEAS:SOUR CHAN1
 Digitize channel 1 DIG CHAN1
 Measure time of 1st positive edge at 0 V .. MEAS:TVOL? 0,+1?

6. Record the measured time that 1st positive edge occurred at 0 V.

T2 = _____.

7. Subtract T1 from T2. The difference should be between 7.890 nsec and 8.110 nsec.

8. Repeat steps 2 through 7 for all the HP E1426A DELay values specified in the table below.

Step 5 TIM:DEL Value	Tolerance	Limits
8 ns (8E-9)	±110 ps	7.890 to 8.110 ns
128 ns (128E-9)	±116 ps	127.884 to 128.116 ns
400 ns (4E-7)	±130 ps	399.870 to 400.130 ns
800 ns (8E-7)	±150 ps	799.850 to 800.150 ns

9. Set the Signal Generator controls as follows:

Frequency 1 MHz
 Output 150 mVrms

10. Set the HP E1426A controls as follows:

Perform an autoscale AUT
 Time base to 2 µsec TIM:RANG 2E-6
 Time base delay to 0 sec TIM:DEL 0
 Measure channel 1 MEAS:SOUR CHAN1
 Digitize channel 1 DIG CHAN1
 Measure time of 1st positive edge at 0 V .. MEAS:TVOL? 0,+1?

11. Record the measured time that 1st positive edge occurred at 0 V.

T3 = _____.

12. Set the HP E1426A controls as follows:

Time base delay to 500 µsec TIM:DEL 5E-4
 Digitize channel 1 DIG CHAN1
 Measure time of 1st positive edge at 0 V .. MEAS:TVOL? 0,+1?

13. Record the measured time that 1st positive edge occurred at 0 V.

T4 = _____.

14. Subtract T3 from T4. The difference should be between 499.9709 µsec and 500.0291 µsec.

15. Disconnect test equipment.

Example This program will automatically prompt the user through the steps required to perform a time accuracy test, and print out the results of each measurement.

The example is written using:

- an HP-IB select code of 7, primary address of 09, and secondary address of 05 for the HP E1426A
- COMPatible programming language
- an HP Series 200/300 Computer with HP BASIC

Execute:

```
10 OPTION BASE 1
20 DIM Delay(4)
30 RESTORE
40 READ Delay(*)
50 OUTPUT 70905;"*CLS"
60 OUTPUT 70905;"*RST"
70 PRINT "Connect the signal generator to scope channel 1"
80 PRINT "Set the signal generator to 500 MHz and 150 mV rms"
90 PAUSE
100 OUTPUT 70905;"TIM:RANG 5E-9"
110 OUTPUT 70905;"TIM:DEL 0"
120 OUTPUT 70905;"VIEW CHAN1"
130 OUTPUT 70905;"BLAN CHAN2,CHAN3,CHAN4"
140 OUTPUT 70905;"CHAN1:COUP DCF"
150 OUTPUT 70905;"ACQ:TYP AVER"
160 OUTPUT 70905;"ACQ:COUN 8"
170 OUTPUT 70905;"CHAN1:RANG .4"
180 OUTPUT 70905;"MEAS:SOUR CHAN1"
190 OUTPUT 70905;"DIG CHAN1"
200 OUTPUT 70905;"MEAS:TVOL? 0,+1"
210 ENTER 70905;Time1
220 FOR Measurement=1 TO 4
230     OUTPUT 70905;"TIM:DEL "&VAL$(Delay(Measurement))
240     OUTPUT 70905;"MEAS:SOUR CHAN1"
250     OUTPUT 70905;"DIG CHAN1"
260     OUTPUT 70905;"MEAS:TVOL? 0,+1"
270     ENTER 70905;Time2
280     PRINT "Delta-t for "&VAL$(Delay(Measurement))&" was "&VAL$(Time2-Time1)
300 NEXT Measurement
310 PRINT "Set the signal generator to 1 MHz and 150 mV rms"
320 PAUSE
330 OUTPUT 70905;"AUTOSCALE"
340 OUTPUT 70905;"TIM:RANG 2E-6"
350 OUTPUT 70905;"TIM:DEL 0"
360 OUTPUT 70905;"MEAS:SOUR CHAN1"
370 OUTPUT 70905;"DIG CHAN1"
380 OUTPUT 70905;"MEAS:TVOL? 0,+1"
390 ENTER 70905;Time3
400 OUTPUT 70905;"TIM:DEL 5E-4"
410 OUTPUT 70905;"DIG CHAN1"
420 OUTPUT 70905;"MEAS:TVOL? 0,+1"
430 ENTER 70905;Time4
440 OUTPUT 70905;"*RST"
450 PRINT "Delta-t for 500E-9 was "&VAL$(Time4-Time3)
460 DATA 8E-9,128E-9,400E-9,800E-9
470 END
```

4-16. Trigger Sensitivity Test Procedure

This test checks channel and external triggers for sensitivity at rated bandwidth.

1. Connect the equipment as shown below. Use an N-to-BNC adapter and BNC cable to connect the signal generator output to the HP E1426A channel 1 input.

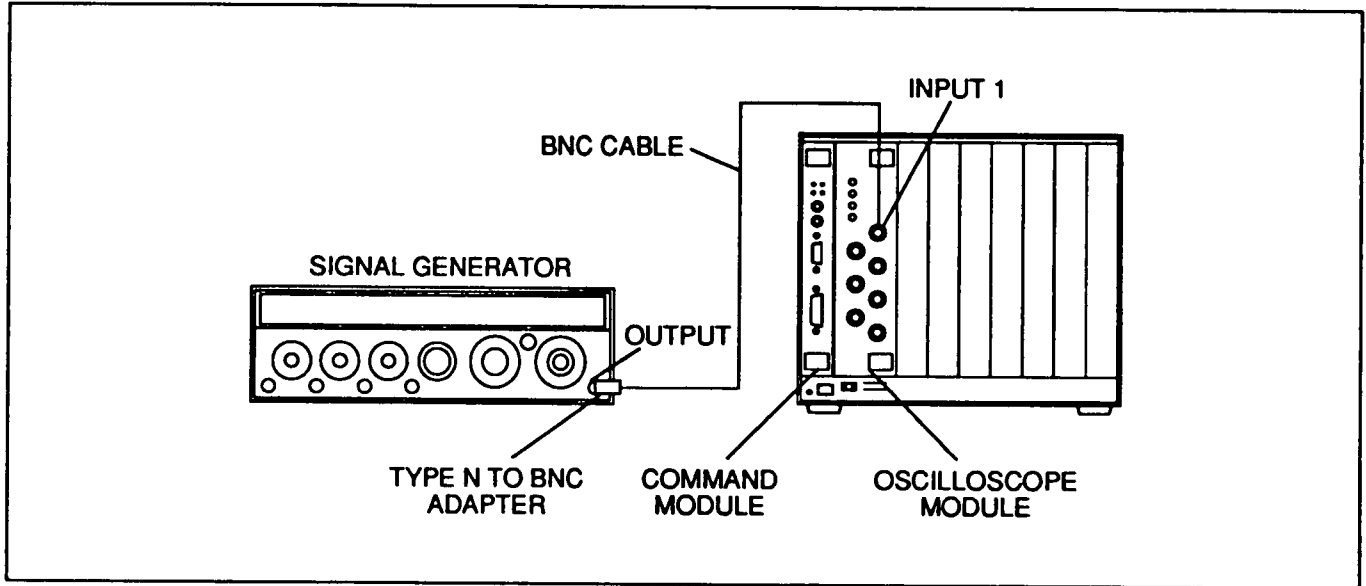

Figure 4-7. Trigger Sensitivity Test Set-up

2. Set the Signal Generator controls as follows:

Frequency 100 MHz
Output 100 mV

3. Set the HP E1426A controls as follows:

Reset HP E1426A *RST
Time base to 20 nsec TIM:RANG 20E-9
Turn on channel 1 VIEW CHAN1
Turn off unused channels BLAN CHAN2,CHAN3,CHAN4
Channel 1 to DC at 50Ω CHAN1:COUP DCF
Channel 1 range to 1.6 V CHAN1:RANG 1.6
Channel 1 offset to 0 V CHAN1:OFFS 0
Acquisition type to average ACQ:TYP AVER
Acquisition count to 16 ACQ:COUN 16
Trigger source to channel 1 TRIG:SOUR CHAN1
Trigger level to 0 V TRIG:LEV 0
Start HP E1426A running RUN

4. On the HP E1426A front panel, verify TRIGGERED LED is ON.

5. Set the Signal Generator controls as follows:

Frequency 500 MHz
Output 250 mV rms

6. Set the HP E1426A controls as follows:
 - Time base to 100 nsec TIM:RANG 1E-7
 - Start HP E1426A running RUN
7. On the HP E1426A front panel, verify TRIGGERED LED is ON.
8. Set the Signal Generator controls as follows:
 - Frequency 500 MHz
 - Output 7.5 mV rms
9. Set the HP E1426A controls as follows:
 - Channel 1 range to 10 mV CHAN1:RANG 1E-2
 - Channel 1 offset to 0 V CHAN1:OFFS 0
 - Start HP E1426A running RUN
10. On the HP E1426A front panel, verify TRIGGERED LED is ON.
11. Set the Signal Generator controls as follows:
 - Frequency 100 MHz
 - Output 3.12 mV rms
12. Set the HP E1426A controls as follows:
 - Time base to 500µsec TIM:RANG 5E-8
 - Start HP E1426A running RUN
13. On the HP E1426A front panel, verify TRIGGERED LED is ON.
14. Connect the signal generator output to the next channel being tested. Repeat steps 2 through 14 for channels 2, 3, and 4.

Notes

When repeating the procedure, all references to channel 1 should be changed to the channel being tested. Turn off all unused channels using the BLANK command.

Trigger errors can be caused by the attenuator or A2 PCA. See troubleshooting in Chapter 8.

15. Disconnect test equipment.

Example

This program will automatically prompt the user through the steps required to perform a trigger sensitivity test.

The example is written using:

- an HP-IB select code of 7, primary address of 09, and secondary address of 05 for the HP E1426A
- COMPatible programming language
- an HP Series 200/300 Computer with HP BASIC

Execute:

```
10 OUTPUT 70905;"*CLS"
20 OUTPUT 70905;"*RST"
30 FOR Channel=1 TO 4
40     PRINT "Connect the signal generator to scope channel "&VAL$(Channel)
50     PAUSE
60     PRINT "Set the signal generator to 100 MHz and 100 mV rms"
70     PAUSE
80     OUTPUT 70905;"TIM:RANG 20E-9"
90     OUTPUT 70905;"BLAN CHAN1,CHAN2,CHAN3,CHAN4"
100    OUTPUT 70905;"VIEW CHAN"&VAL$(Channel)
110    OUTPUT 70905;"CHAN"&VAL$(Channel)&":COUP DCF"
120    OUTPUT 70905;"CHAN"&VAL$(Channel)&":RANG 1.6"
130    OUTPUT 70905;"ACQ:TYP AVER"
140    OUTPUT 70905;"ACQ:COUN 16"
150    OUTPUT 70905;"TRIG:SOUR CHAN"&VAL$(Channel)
160    OUTPUT 70905;"TRIG:LEV 0"
170    OUTPUT 70905;"RUN"
180    PRINT "Triggered?"
190    PAUSE
200    PRINT "Set the signal generator to 500 MHz and 250 mV rms"
210    PAUSE
220    OUTPUT 70905;"TIM:RANG 1E-7"
230    OUTPUT 70905;"RUN"
240    PRINT "Triggered?"
250    PAUSE
260    PRINT "Set the signal generator to 500 MHz and 7.5 mV rms"
270    PAUSE
280    OUTPUT 70905;"CHAN"&VAL$(Channel)&":RANG 1E-2"
290    OUTPUT 70905;"CHAN"&VAL$(Channel)&":OFFS 0"
300    OUTPUT 70905;"RUN"
310    PRINT "Triggered?"
320    PAUSE
330    PRINT "Set the signal generator to 100 MHz and 3.12 mV rms"
340    OUTPUT 70905;"TIM:RANG 5E-8"
350    OUTPUT 70905;"RUN"
360    PRINT "Triggered?"
370    PAUSE
380 NEXT Channel
390 OUTPUT 70905;"*RST"
400 END
```

4-17. Oscillator Output Test Procedure

This test is optional. The oscillator outputs are not specified in the instrument performance specifications. The values given are typical. Results are not recorded in the test record.

1. Connect the equipment as shown below. Channels 2-4 must be disconnected.

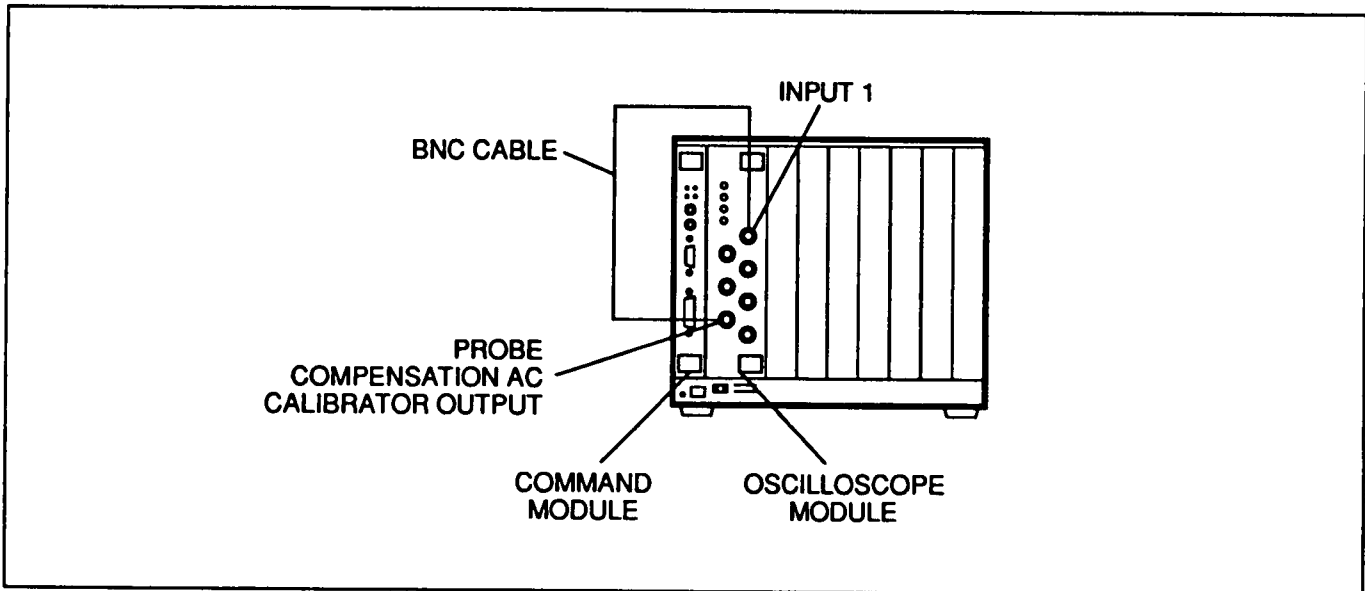

Figure 4-8. Oscillator Output Test Set-up

2. Set the HP E1426A controls as follows:

```

Reset HP E1426A ..... *RST
Perform an Autoscale function ..... AUT
Channel 1 to DC at 1MΩ ..... CHAN1:COUP DC
Digitize channel 1 ..... DIG CHAN1
Measure channel 1 frequency ..... MEAS:FREQ?
Digitize channel 1 ..... DIG CHAN1
Measure channel 1 peak-to-peak voltage ..... MEAS:VPP?
    
```

3. Verify the measured results are ≈ 1.5 kHz at ≈ 800 mV.

4. Set the HP E1426A controls as follows:

```

Channel 1 to DC at 50Ω ..... CHAN1:COUP DCF
Digitize channel 1 ..... DIG CHAN1
Measure channel 1 peak-to-peak voltage ..... MEAS:VPP?
    
```

5. Verify the measured peak-to-peak voltage into 50Ω is ≈ 400 mV.

6. Remove power and disconnect test equipment.

Example This program will automatically perform an oscillator output test, and print the measurement results.

The example is written using:

- an HP-IB select code of 7, primary address of 09, and secondary address of 05 for the HP E1426A
- COMPAtible programming language
- an HP Series 200/300 Computer with HP BASIC

Execute:

```
10  OUTPUT 70905;"+CLS"
20  OUTPUT 70905;"+RST"
30  OUTPUT 70905;"AUT"
40  OUTPUT 70905;"CHAN1:COUP DC"
50  OUTPUT 70905;"DIG CHAN1"
60  OUTPUT 70905;"MEAS:SOUR CHAN1"
70  OUTPUT 70905;"DIG CHAN1"
80  OUTPUT 70905;"MEAS:FREQ?"
90  ENTER 70905;Freq_
100 PRINT Freq_
110 OUTPUT 70905;"MEAS:VPP?"
120 ENTER 70905;Vpp_dc
130 PRINT Vpp_dc
140 OUTPUT 70905;"CHAN1:COUP DCF"
150 OUTPUT 70905;"DIG CHAN1"
160 OUTPUT 70905;"MEAS:VPP?"
170 ENTER 70905;Vpp_dcf
180 PRINT Vpp_dcf
190 END
```

Table 4-1. Verification Test Record

Hewlett-Packard Company				
Model HP E1426A		Tested by _____		
C Size VXI Oscilloscope Module		Work Order No. _____		
√ Recommended test interval [] 6 months [] 1000 hours		Recommended next testing _____		
Serial Number _____		Temperature _____	Date _____	

Para. No.	Test	Min.	Results Actual	Max.
	FUNCTIONAL VERIFICATION			
4-7	Self Test Test passes (+0 returned)		[√] _____	
	PERFORMANCE VERIFICATION			
4-10	DC Calibrator Test Calculated Difference (0 and 5 V)	4.990 Vdc	_____	5.010 Vdc
4-11	Input Resistance Test			
	CHAN 1			
	1MΩ	990 kΩ	_____	1.010 MΩ
	50Ω	49.50Ω	_____	50.50Ω
	CHAN 2			
	1MΩ	990 kΩ	_____	1.010 MΩ
	50Ω	49.50Ω	_____	50.50Ω
	CHAN 3			
	1MΩ	990 kΩ	_____	1.010 MΩ
	50Ω	49.50Ω	_____	50.50Ω
	CHAN 4			
	1MΩ	990 kΩ	_____	1.010 MΩ
	50Ω	49.50Ω	_____	50.50Ω
4-12	Voltage Measurement Accuracy Test			
	CHAN 1			
	40 V Range	34.5 V	_____	35.5 V
	16 V Range	13.8 V	_____	14.2 V
	8 V Range	6.9 V	_____	7.1 V
	4 V Range	3.45 V	_____	4.05 V
	1.6 V Range	1.38 V	_____	1.42 V
	800 mV Range	690 mV	_____	710 mV
	400 mV Range	345 mV	_____	355 mV
	160 mV Range	138 mV	_____	142 mV
	80 mV Range	69 mV	_____	71 mV
	40 mV Range	34.3 mV	_____	35.7 mV
	16 mV Range	13.3 mV	_____	14.7 mV
	8 mV Range	6.3 mV	_____	7.7 mV

Table 4-1. Verification Test Record — Continued

Para- No.	Test	Min.	Results Actual	Max.	
4-12	PERFORMANCE VERIFICATION — Continued				
	Voltage Measurement Accuracy Test — Cont				
	CHAN 2				
	40 V Range	34.5 V	_____	35.5 V	
	16 V Range	13.8 V	_____	14.2 V	
	8 V Range	6.9 V	_____	7.1 V	
	4 V Range	3.45 V	_____	4.05 V	
	1.6 V Range	1.38 V	_____	1.42 V	
	800 mV Range	690 mV	_____	710 mV	
	400 mV Range	345 mV	_____	355 mV	
	160 mV Range	138 mV	_____	142 mV	
	80 mV Range	69 mV	_____	71 mV	
	40 mV Range	34.3 mV	_____	35.7 mV	
	16 mV Range	13.3 mV	_____	14.7 mV	
	8 mV Range	6.3 mV	_____	7.7 mV	
	CHAN 3				
	40 V Range	34.5 V	_____	35.5 V	
	16 V Range	13.8 V	_____	14.2 V	
	8 V Range	6.9 V	_____	7.1 V	
	4 V Range	3.45 V	_____	4.05 V	
	1.6 V Range	1.38 V	_____	1.42 V	
	800 mV Range	690 mV	_____	710 mV	
	400 mV Range	345 mV	_____	355 mV	
	160 mV Range	138 mV	_____	142 mV	
	80 mV Range	69 mV	_____	71 mV	
	40 mV Range	34.3 mV	_____	35.7 mV	
	16 mV Range	13.3 mV	_____	14.7 mV	
	8 mV Range	6.3 mV	_____	7.7 mV	
	CHAN 4				
	40 V Range	34.5 V	_____	35.5 V	
	16 V Range	13.8 V	_____	14.2 V	
	8 V Range	6.9 V	_____	7.1 V	
	4 V Range	3.45 V	_____	4.05 V	
	1.6 V Range	1.38 V	_____	1.42 V	
	800 mV Range	690 mV	_____	710 mV	
	400 mV Range	345 mV	_____	355 mV	
	160 mV Range	138 mV	_____	142 mV	
	80 mV Range	69 mV	_____	71 mV	
	40 mV Range	34.3 mV	_____	35.7 mV	
	16 mV Range	13.3 mV	_____	14.7 mV	
	8 mV Range	6.3 mV	_____	7.7 mV	

Table 4-1. Verification Test Record — Continued

Para. No.	Test	Min.	Results Actual	Max.
4-13	PERFORMANCE VERIFICATION — Continued			
	Offset Accuracy Test			
	CHAN 1			
	20 V Offset	19.820 V	_____	20.180 V
	9 V Offset	8.923 V	_____	9.077 V
	5 V Offset	4.959 V	_____	5.041 V
	CHAN 2			
	20 V Offset	19.820 V	_____	20.180 V
	9 V Offset	8.923 V	_____	9.077 V
	5 V Offset	4.959 V	_____	5.041 V
	CHAN 3			
	20 V Offset	19.820 V	_____	20.180 V
	9 V Offset	8.923 V	_____	9.077 V
	5 V Offset	4.959 V	_____	5.041 V
	CHAN 4			
	20 V Offset	19.820 V	_____	20.180 V
9 V Offset	8.923 V	_____	9.077 V	
5 V Offset	4.959 V	_____	5.041 V	
4-14	Bandwidth Test			
	CHAN 1			
	≥80 mV Full Scale Range at 500 MHz	≤-3.0 dB	_____	
	<80 mV Full Scale Range at 500 MHz	≤-3.5 dB	_____	
	CHAN 2			
	≥80 mV Full Scale Range at 500 MHz	≤-3.0 dB	_____	
	<80 mV Full Scale Range at 500 MHz	≤-3.5 dB	_____	
	CHAN 3			
	≥80 mV Full Scale Range at 500 MHz	≤-3.0 dB	_____	
	<80 mV Full Scale Range at 500 MHz	≤-3.5 dB	_____	
	CHAN 4			
	≥80 mV Full Scale Range at 500 MHz	≤-3.0 dB	_____	
<80 mV Full Scale Range at 500 MHz	≤-3.5 dB	_____		
4-15	Time Measurement Accuracy Test			
	8 nsec	7.890 ns	_____	8.110 ns
	128 nsec	127.884 ns	_____	128.116 ns
	400 nsec	399.870 ns	_____	400.130 ns
	800 nsec	799.850 ns	_____	800.150 ns

Table 4-1. Verification Test Record — Continued

Para. No.	Test	Min.	Results Actual	Max.	
4-16	PERFORMANCE VERIFICATION — Continued				
	Trigger Sensitivity Test				
	CHAN 1				
	1.6 V Range at 100 MHz	Triggered LED ON		[√] _____	
	1.6 V Range at 500 MHz	Triggered LED ON		[√] _____	
	10 mV Range at 500 MHz	Triggered LED ON		[√] _____	
	10 mV Range at 100 MHz	Triggered LED ON		[√] _____	
	CHAN 2				
	1.6 V Range at 100 MHz	Triggered LED ON		[√] _____	
	1.6 V Range at 500 MHz	Triggered LED ON		[√] _____	
	10 mV Range at 500 MHz	Triggered LED ON		[√] _____	
	10 mV Range at 100 MHz	Triggered LED ON		[√] _____	
	CHAN 3				
	1.6 V Range at 100 MHz	Triggered LED ON		[√] _____	
	1.6 V Range at 500 MHz	Triggered LED ON		[√] _____	
	10 mV Range at 500 MHz	Triggered LED ON		[√] _____	
10 mV Range at 100 MHz	Triggered LED ON		[√] _____		
CHAN 4					
1.6 V Range at 100 MHz	Triggered LED ON		[√] _____		
1.6 V Range at 500 MHz	Triggered LED ON		[√] _____		
10 mV Range at 500 MHz	Triggered LED ON		[√] _____		
10 mV Range at 100 MHz	Triggered LED ON		[√] _____		
4-17	Oscillator Output Test				
	AC Calibrator Signal		[√] _____		

Adjustments

5-1. Introduction

This chapter contains adjustments that assure peak performance of the HP E1426A Oscilloscope. This instrument should be adjusted after repair to assure performance.

Some Oscilloscope adjustments are performed electrically, meaning a manual adjustment on a particular component is not necessary. The order in which the adjustments are made is critical. Perform adjustments in the order given.

Note

To consider the tests valid, the following conditions must be met:

- The Oscilloscope must have a 30 minute warm-up at ambient temperature installed in the mainframe.
 - The line voltage must be 115/230 Vac $\pm 10\%$.
 - For greatest accuracy, the temperature of the test area should be between 18°C and 28°C and should be stable within $\pm 1^\circ\text{C}$.
-

5-2. Equipment Required

Equipment required for the adjustment procedures is listed in Table 1-1, Recommended Test Equipment. Any equipment that satisfies the critical specifications given in the table may be substituted.

Caution

Do not remove the module with power applied to the mainframe.

The firmware calibration procedures should only be performed after the instrument has run for one half hour at ambient temperature installed in the mainframe.

Notes

All firmware calibration/adjustment procedures should be done in the order given.

After calibrating, you **MUST** perform an AUToscale or *RST (reset) to return to normal operation.

5-3. Vertical Calibration Procedure

Vertical calibration is performed on channels one through four (simultaneously) using the following procedure:

1. Set the CAL FACTOR PROTECT switch to UNPROTECTED.
2. Connect the Oscilloscope DC Calibrator Output connector to the Input 1-4 connectors.

Note

Verify that the BNC cables are not longer than 1 meter and as close in length as possible.

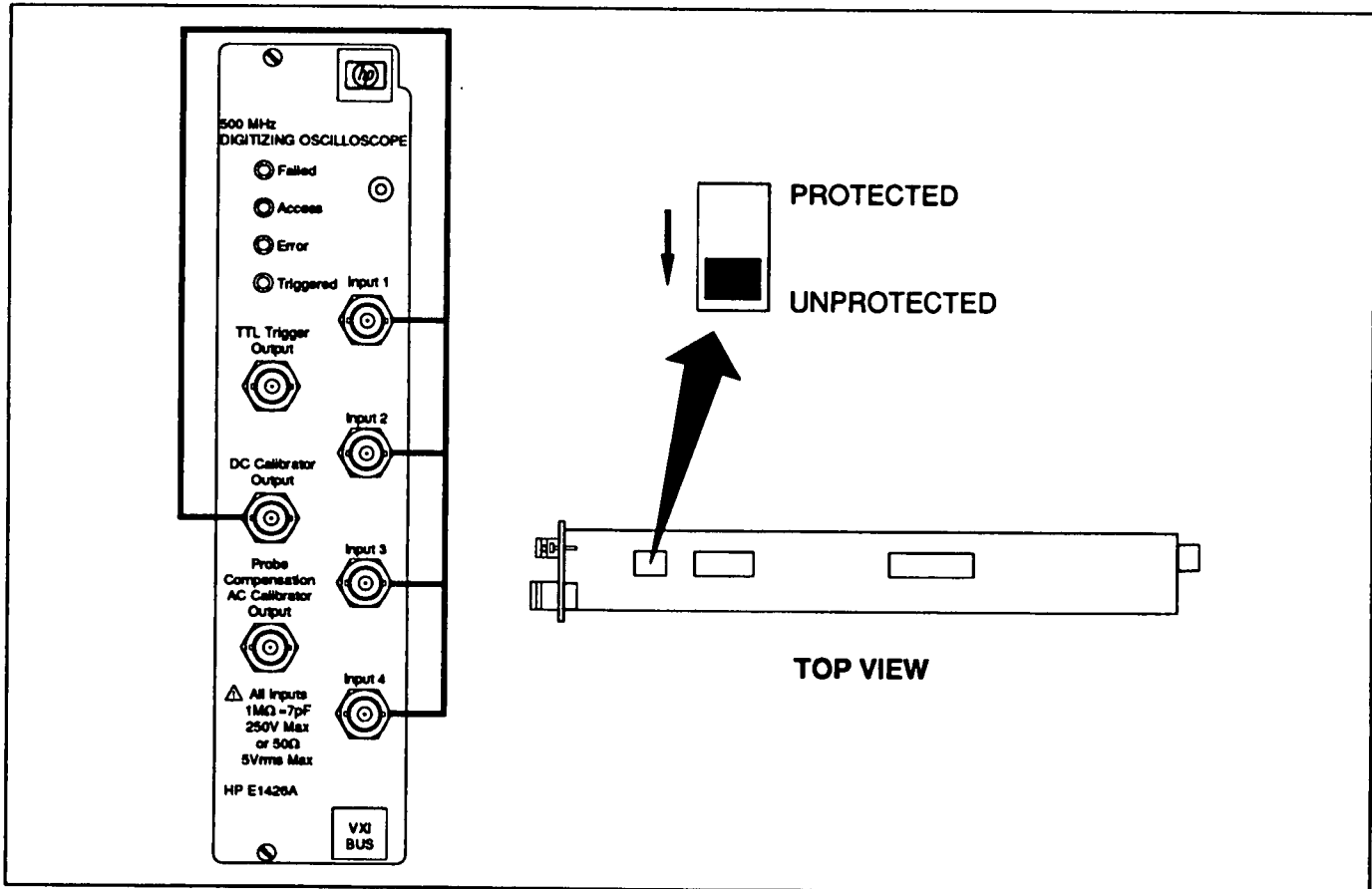

Figure 5-1. Example: Vertical Calibration Setup

3. Load the "default" calibration data.
4. Perform clear status, reset, then preset the Oscilloscope.
5. Select and start the vertical calibration routine. Calibration will last for approximately 15 minutes. During calibration, the access and error LED's will be on.

Note

If the calibration time exceeds 15 minutes, the calibration is invalid. Recycle power then repeat procedure. If the condition repeats, the instrument is malfunctioning. Refer to the Service Manual for information on correcting the malfunction before proceeding.

6. After calibration is complete (LED's to off), read the calibration event register to verify that no errors were generated during the procedure.
 - If "0" is returned, the calibration was successful.
 - If "0" is not returned, the calibration attempt was unsuccessful. See Chapter 4, CALibrate Subsystem for more information.
7. Disconnect cables and perform Delay Calibration Procedure.

Example

The following example shows how to perform a vertical calibration. The example is written using:

- an HP-IB select code of 7, primary address of 09, and secondary address of 05 for the Oscilloscope
- COMPatible programming language
- an HP Series 200/300 Computer with HP BASIC

Execute:

10	OUTPUT 70905;"CAL:SCAL:DCAL"	<i>Selects default calibration routine.</i>
20	OUTPUT 70905;"CAL:SCAL:BCAL"	<i>Load default calibration data.</i>
30	OUTPUT 70905;"*CLS"	<i>Clear status.</i>
40	OUTPUT 70905;"*RST"	<i>Resets the Oscilloscope to its default state.</i>
50	OUTPUT 70905;"SUMM:PRES"	<i>Presets the Oscilloscope.</i>
60	OUTPUT 70905;"CAL:SCAL:VERT"	<i>Selects vertical calibration routine.</i>
70	OUTPUT 70905;"CAL:SCAL:BCAL"	<i>Starts vertical calibration routine.</i>
80	OUTPUT 70905;"SUMM:QUES:CAL?"	<i>Read calibration event register.</i>
90	ENTER 70905;A	<i>Enter calibration event register results.</i>
100	PRINT A	<i>Print calibration event register results.</i>
110	END	<i>Terminate program.</i>

5-4. Delay Cal Calibration Procedure

Delay calibration is performed on channels one through four (one at a time) using the following procedure:

1. Verify the CAL FACTOR PROTECT switch is set to **UNPROTECTED**.
2. Connect the Oscilloscope AC Calibrator Output connector to the Input 1 connector using a BNC cable.

Note

Verify that the BNC cable is not longer than 1 meter.

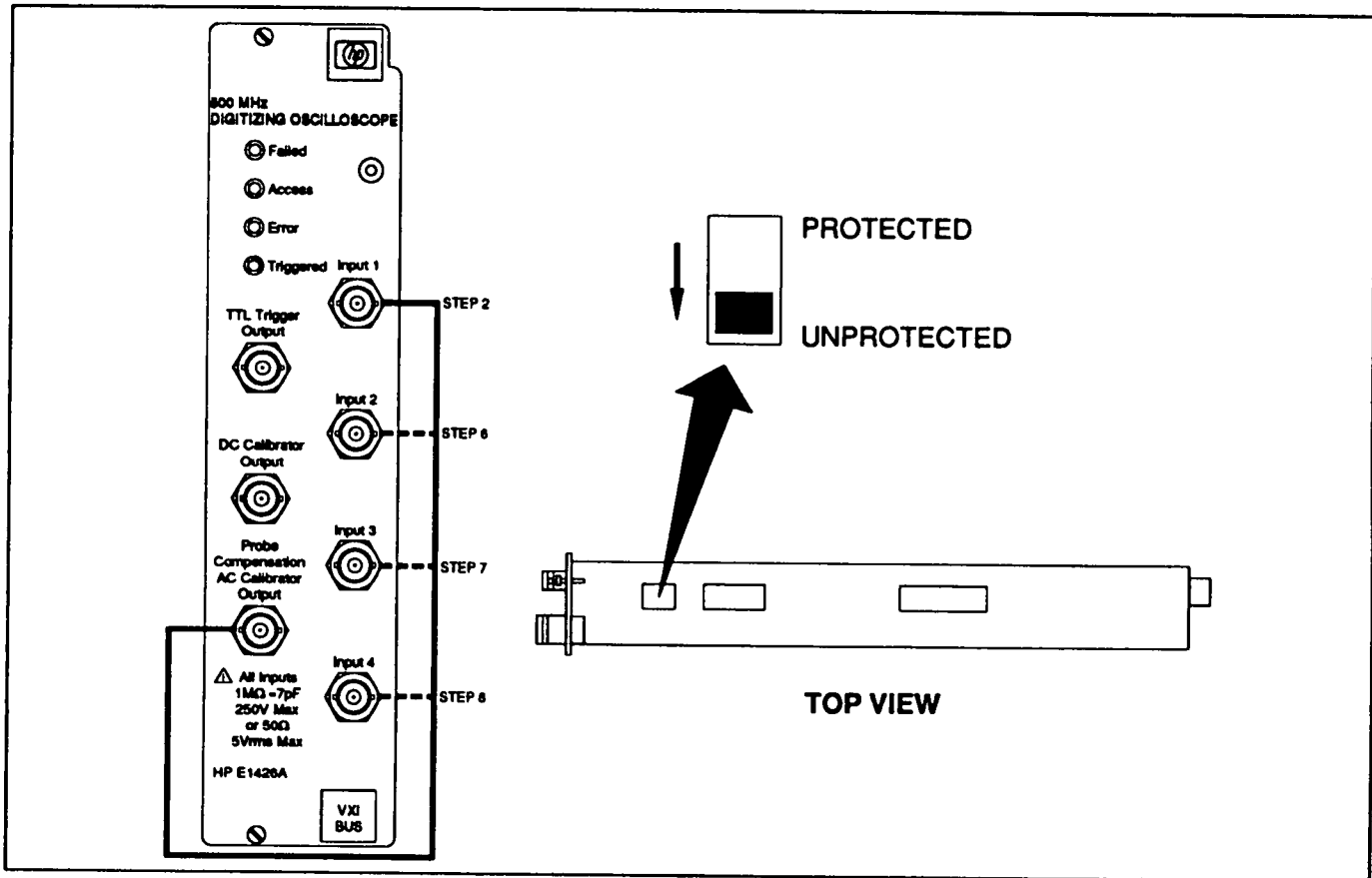

Figure 5-2. Example: Delay Calibration Setup

3. Perform clear status, reset, then preset the Oscilloscope.
4. Select and start the delay calibration routine. During calibration, the access and error LED's will be on.

Note

If the calibration time exceeds 1 minute, the calibration is invalid. Recycle power then repeat procedure. If the condition repeats the instrument is malfunctioning. Refer to the Service Manual for information on correcting the malfunction before proceeding.

5. After calibration is complete (LED's to off), read the calibration event register to verify that no errors were generated during the procedure.
 - If "0" is returned, the calibration was successful.
 - If "0" is not returned, the calibration attempt was unsuccessful. See Chapter 4, CALibrate Subsystem for more information.
6. Disconnect cable from input 1 and reconnect to input 2. Repeat steps 4 and 5 for input 2.
7. Disconnect cable from input 2 and reconnect to input 3. Repeat steps 4 and 5 for input 3.
8. Disconnect cable from input 3 and reconnect to input 4. Repeat steps 4 and 5 for input 4.
9. When complete, disconnect BNC cable and perform Time Null Calibration Procedure.

Example

The following example shows how to perform a delay calibration. The example is written using:

- an HP-IB select code of 7, primary address of 09, and secondary address of 05 for the Oscilloscope
- COMPatible programming language
- an HP Series 200/300 Computer with HP BASIC

Execute:

```
10 OUTPUT 70905;"*CLS"           Clear status.
20 OUTPUT 70905;"*RST"           Resets the Oscilloscope to its default
                                  state.
30 OUTPUT 70905;"SUMM:PRES"       Presets the Oscilloscope.
40 FOR I=1 TO 4                   Input testing loop.
50 OUTPUT 70905;"CAL:SCAL:DEL CHAN"&VALS(I) Selects input n delay calibration
                                  routine (n=input 1-4).
60 OUTPUT 70905;"CAL:SCAL:BCAL"    Starts delay calibration routine.
70 OUTPUT 70905;"SUMM:QUES:CAL?"  Read calibration event register.
80 ENTER 70905;B                  Enter calibration event register results.
90 PRINT B                        Print calibration event register results.
100 PAUSE                          Pause to connect next input.
110 NEXT I                         Repeat for inputs 2-4.
120 END                            Terminate program.
```

5-5. Time Null Calibration Procedure

Time Null calibration is performed on channels one-two, one-three, and one-four (one at a time) using the following procedure:

1. Verify the CAL FACTOR PROTECT switch is set to **UNPROTECTED**.
2. Connect the Oscilloscope AC Calibrator Output connector to both the Input 1 and Input 2 connectors.

Note

Verify that the BNC cables are not longer than 1 meter and equal in length.

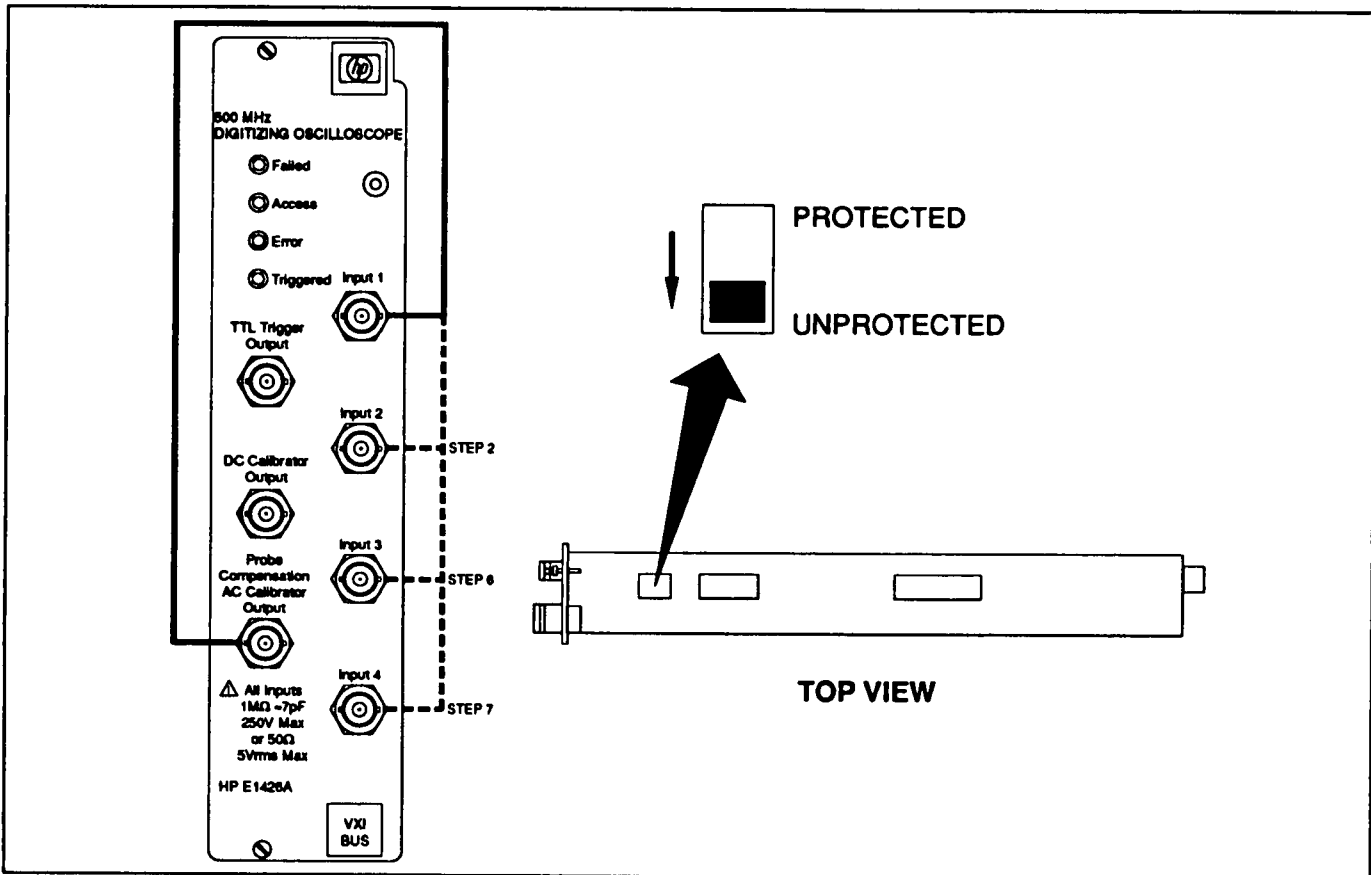

Figure 5-3. Example: Time Null Calibration Setup

3. Perform clear status, reset, then preset the Oscilloscope.
4. Select and start the time null calibration routine. During calibration, the access and error LED's will be on.

Note

If the calibration time exceeds 1 minute, the calibration is invalid. Recycle power then repeat procedure. If the condition repeats the instrument is malfunctioning. Refer to the Service Manual for information on correcting the malfunction before proceeding.

5. After calibration is complete (LED's to off), read the calibration event register to verify that no errors were generated during the procedure.
 - If "0" is returned, the calibration was successful.
 - If "0" is not returned, the calibration attempt was unsuccessful. See Chapter 4, CALibrate Subsystem for more information.
6. Disconnect cable from input 2 and reconnect to input 3. Repeat steps 4 and 5 for input 3.
7. Disconnect cable from input 3 and reconnect to input 4. Repeat steps 4 and 5 for input 4.
8. When complete, disconnect BNC cable and perform the Logic Trigger Calibration Procedure (if necessary).

Example

The following example shows how to perform a time null calibration. The example is written using:

- an HP-IB select code of 7, primary address of 09, and secondary address of 05 for the Oscilloscope
- COMPatible programming language
- an HP Series 200/300 Computer with HP BASIC

Execute:

10 OUTPUT 70905;"*CLS"	<i>Clear status.</i>
20 OUTPUT 70905;"*RST"	<i>Resets the Oscilloscope to its default state.</i>
30 OUTPUT 70905;"SUMM:PRES"	<i>Presets the Oscilloscope.</i>
40 FOR I=2 TO 4	<i>Input testing loop.</i>
50 OUTPUT 70905;"CAL:SCAL:TNUL CH1TO"&VAL\$(I)	<i>Selects channel 1 to n time null calibration routine (n=input 2-4).</i>
60 OUTPUT 70905;"CAL:SCAL:BCAL"	<i>Starts time null calibration routine.</i>
70 OUTPUT 70905;"SUMM:QUES:CAL?"	<i>Read calibration event register.</i>
80 ENTER 70905;C	<i>Enter calibration event register results.</i>
90 PRINT C	<i>Print calibration event register results.</i>
100 PAUSE	<i>Pause to connect next input.</i>
110 NEXT I	<i>Repeat for inputs 3-4.</i>
120 END	<i>Terminate program.</i>

5-6. Logic Trigger Calibration Procedure

Logic trigger calibration is performed on channel one using the following procedure:

1. Verify the CAL FACTOR PROTECT switch is set to **UNPROTECTED**.
2. Connect the Oscilloscope AC Calibrator Output connector to the Input 1 connector using a BNC cable.

Note

Verify that the BNC cable is not longer than 1 meter.

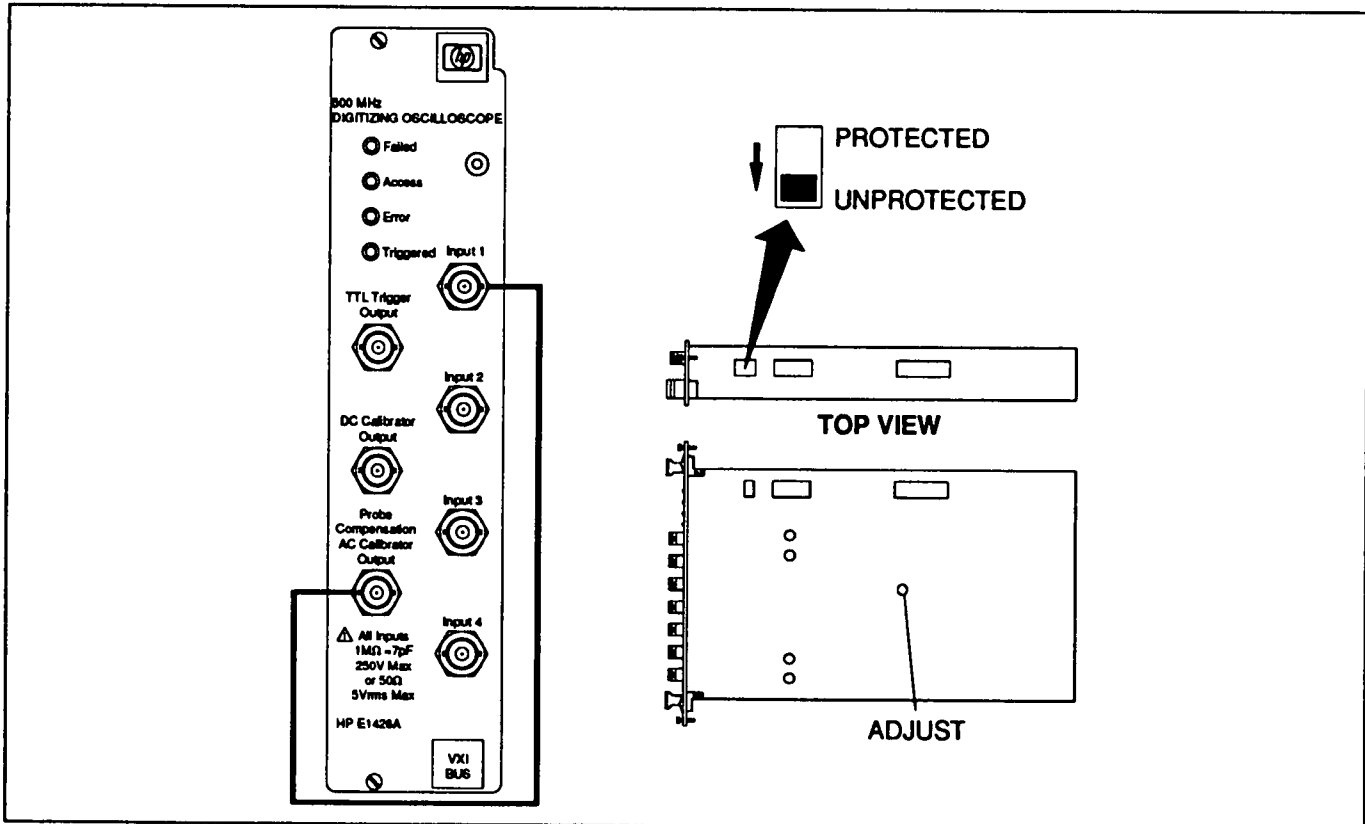

Figure 5-4. Example: Logic Trigger Calibration Setup

3. Read the calibration register to verify that no errors are present.
 - If "0" is returned, proceed with step 5.
 - If "0" is not returned, the Logic Trigger calibration must be terminated, and the cause of the error corrected. See Chapter 4, CALibrate Subsystem for more information.
4. Perform clear status, reset, then preset the Oscilloscope.

5. Locate the logic trigger adjustment on the right side of the Oscilloscope module, and the error and access LED's on the front panel.
6. Select and start the logic trigger calibration routine. Verify that the triggered LED flashes.

Observe the access and error LED's.

- If both are on, no adjustment is required.
- If only one is ON, rotate the logic trigger adjustment until both LED's remain ON.

Approximately 15 seconds after no further rotation of the adjustment, the triggered LED will flash faster, then all LED's will go out.

7. After calibration is complete (LED's to off), read the calibration register to verify that no errors were generated during the procedure.
 - If "0" is returned, the calibration was successful.
 - If "0" is not returned, the calibration attempt was unsuccessful. See Chapter 4, CALibrate Subsystem for more information.
8. Disconnect BNC cable and set the CAL FACTOR PROTECT switch to PROTECTED.

Example

The following example shows how to perform a logic trigger calibration. The example is written using:

- an HP-IB select code of 7, primary address of 09, and secondary address of 05 for the Oscilloscope
- COMPatible programming language
- an HP Series 200/300 Computer with HP BASIC

Execute:

10 OUTPUT 70905; "*CLS"	<i>Clear status.</i>
20 OUTPUT 70905; "*RST"	<i>Resets the Oscilloscope to its default state.</i>
30 OUTPUT 70905; "SUMM: PRES"	<i>Presets the Oscilloscope.</i>
40 OUTPUT 70905; "SUMM: QUES: CAL?"	<i>Read calibration event register.</i>
50 ENTER 70905; D	<i>Enter calibration event register results.</i>
60 PRINT D	<i>Print calibration event register results.</i>
70 IF D<>0 THEN 130	<i>Terminate if results not 0.</i>
80 OUTPUT 70905; "CAL: SCAL: LTC"	<i>Selects logic trigger calibration routine.</i>
90 OUTPUT 70905; "CAL: SCAL: BCAL"	<i>Starts logic trigger calibration routine.</i>
100 OUTPUT 70905; "SUMM: QUES: CAL?"	<i>Read calibration event register.</i>
110 ENTER 70905; E	<i>Enter calibration event register results.</i>
120 PRINT E	<i>Print calibration event register results.</i>
130 END	<i>Terminate program.</i>

5-7. High Frequency Pulse Response Adjustment Procedure

A High Frequency Pulse Response adjustment is performed by adjusting the overshoot of the input signal to $+3\% \pm 0.5\%$. VBASE and VTOP are measured, then VMAX is measured and overshoot is calculated as a percentage of amplitude.

Pulse response characteristics are such that a secondary peak (ringing) can possibly give incorrect overshoot readings. By delaying the ringing, a valid overshoot measurement can be performed.

Note

This adjustment is performed **ONLY** when a vertical attenuator (AT1-4) has been replaced, or if the Bandwidth test fails. A complete firmware calibration (paragraphs 5-3 through 5-6) **MUST** be completed prior to this adjustment.

If this procedure is not performed, set the CAL FACTOR PROTECT switch to **PROTECTED**.

1. Verify the CAL FACTOR PROTECT switch is set to **UNPROTECTED**. Locate the resistor on the channel that is being adjusted, and set it to mechanical center.
 - AT1 (channel 1) is A2 R501.
 - AT2 (channel 2) is A2 R502.
 - AT3 (channel 3) is A2 R503.
 - AT4 (channel 4) is A2 R504.
2. Connect the equipment as shown below. Pulse Generator output is connected to the Input connector of the channel that is being adjusted using a type N cable (3 foot) and adapters (see table 1-1).
3. Apply power to the Pulse Generator.
4. Set the Oscilloscope controls (on the channel being adjusted) as follows:
 - Reset Oscilloscope *RST
 - Coupling to DC at 50Ω CHAN<n>:COUP DCF
 - Perform an Autoscale AUT
 - Channel Range to 800 mV CHAN<n>:RANG 800E-3
 - Channel Offset to 0.1V CHAN<n>:OFFS 0.1
 - Time Base Range to 20 nsec TIM:RANG 20E-9
 - Time Base Delay to -1.9 nsec TIM:DEL -1.9E-9
 - Digitize the channel being adjusted DIG CHAN<n>
 - Measure VBASE MEAS:SOUR CHAN<n>;VBASE?
 - Verify measured result is ≤ 100
 - Measure VTOP MEAS:SOUR CHAN<n>;VTOP?
 - Verify measured result is ≤ 100
 - If VBASE measured result is >100 , an invalid measurement has occurred due to invalid data. Find the cause and correct before continuing.
 - If VTOP measured result is >100 , an invalid measurement has occurred due to invalid data. Find the cause and correct before continuing.
 - If correct, proceed with step 5.

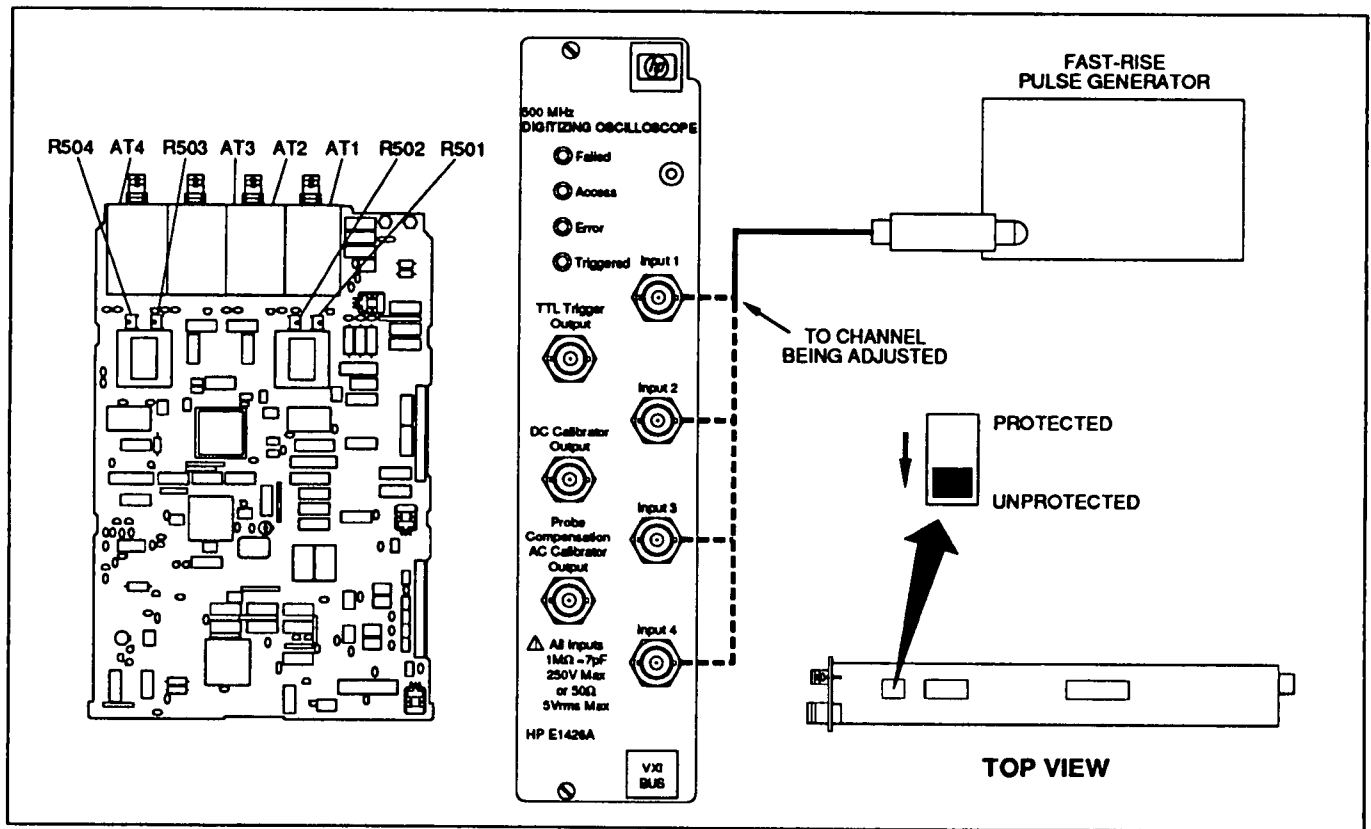

Figure 5-5. High Frequency Pulse Response Adjustment Setup

5. Set the Oscilloscope controls (on the channel being adjusted) as follows:

Time Base Range to 5 nsec TIM:RANG 5E-9
 Time Base Delay to -1.4 nsec TIM:DEL -1.4E-9
 Digitize the channel being adjusted DIG CHAN<n>
 Measure VMAX MEAS:SOUR CHAN<n>;VMAX?
 Verify measured result is ≤ 100

- If VMAX measured result is > 100 , an invalid measurement has occurred. Find the cause and correct before continuing.
 - If correct, proceed with step 6.
6. Calculate overshoot $(V_{MAX} - V_{TOP}) / (V_{TOP} - V_{BASE}) * 100$, Verify calculated overshoot results are $3\% \pm 0.5\%$.
 - If correct, proceed with step 7.
 - If incorrect, adjust the applicable resistor (A2R501 through R504, depending on the channel being adjusted) and repeat the procedure.
 7. Disconnect test equipment and set the CAL FACTOR PROTECT switch to PROTECTED.

Example The following example shows how to perform a High Frequency Pulse Response Adjustment procedure. The example is written using:

- an HP-IB select code of 7, primary address of 09, and secondary address of 05 for Scope
- COMPAtible programming language
- an HP Series 200/300 Computer with HP BASIC

Execute:

```
10 Address=70905
20 Channel=1
30 Retry: !
40 PRINT "Connect the pulse generator to channel "&VAL$(Channel)&" on the oscilloscope"
50 PRINT "Press the return key when ready..."
60 INPUT A$
70 !
80 Retry1: !
90 CLEAR Address
100 OUTPUT Address;"*RST"
110 WAIT 2
120 OUTPUT Address;":CHANNEL"&VAL$(Channel)&":COUPLING DCF"
130 OUTPUT Address;":AUTOSCALE"
140 WAIT 10
150 OUTPUT Address;":CHANNEL"&VAL$(Channel)&":RANGE 800E-3;OFFSET .1"
160 OUTPUT Address;":TIMEBASE:RANGE 20E-9;DEL 1.5E-9"
170 OUTPUT Address;":DIG CHAN"&VAL$(Channel)
180 WAIT 5
190 !
200 OUTPUT Address;":MEASURE:VBASE?"
210 ENTER Address;Vbase
220 PRINT "VBASE = "&VAL$(Vbase)
230 IF Vbase>100 THEN GOTO Meas_error
240 !
250 OUTPUT Address;":MEASURE:VTOP?"
260 ENTER Address;Vtop
270 PRINT "VTOP = "&VAL$(Vtop)
280 IF Vtop>100 THEN GOTO Meas_error
290 !
300 OUTPUT Address;":TIMEBASE:RANGE 5E-9;DELAY -1.4E-9"
310 OUTPUT Address;":DIG CHAN"&VAL$(Channel)
320 WAIT 5
330 !
340 OUTPUT Address;":MEASURE:VMAX?"
350 ENTER Address;Vmax
360 PRINT "VMAX = "&VAL$(Vmax)
370 IF Vmax>100 THEN GOTO Meas_error
380 !
390 Overshoot=(Vmax-Vtop)/(Vtop-Vbase)*100
400 IF Overshoot>3.5 OR Overshoot <2.5 THEN
410 PRINT "Overshoot = "&VAL$(Overshoot)&"%"
420 PRINT "Overshoot out of the specified range..."
430 INPUT A$
440 GOTO Retry1
450 END IF
460 !
470 PRINT "Overshoot is within range..."
480 PRINT "END."
490 GOTO The_end
500 !
510 Meas_error: !
520 PRINT "The measurements were out of range..."
530 GOTO Retry
540 !
550 The_end: !
560 END
```

Replaceable Parts

6-1. Introduction

This chapter contains information for ordering parts. Table 6-1 lists exchange assemblies. Table 6-2 lists abbreviations used in the parts list and the manual. Table 6-3 lists all replaceable parts in reference designator order. Table 6-4 contains the names and addresses that correspond to the manufacturer's code numbers.

6-2. Ordering Information

To order a part listed in the replaceable parts table, quote the Hewlett-Packard part number (with the check digit), indicate the quantity required, and address the order to the nearest Hewlett-Packard office. The check digit will ensure accurate and timely processing of your order.

To order a part that is not listed in the replaceable parts table, include the instrument model number, instrument serial number, description and function of the part, and the number of parts required. Address the order to the nearest Hewlett-Packard office.

6-3. Exchange Assemblies

Table 6-1 lists assemblies within the instrument that may be replaced on an exchange basis. Exchange, factory-repaired and tested assemblies are available only on a trade-in basis. Defective assemblies must be returned for credit. Assemblies required for spare parts stock must be ordered by the new assembly part number.

6-4. Abbreviations

Table 6-2 lists reference designators and abbreviations used in the parts list, schematics, and throughout the manual. In some cases, two forms of the abbreviation are used, one all in capital letters, and one with partial or no capitals. This occurs because the abbreviations in the parts list are always all capitals. However, in the schematics and other parts of the manual, other abbreviation forms are used with both lower case and upper-case letters.

6-5. Replaceable Parts List

Table 6-3 is the list of replaceable parts and is organized as follows:

- a. Electrical assemblies and their components in alpha-numerical order by reference designation.
- b. Chassis-mounted parts in alpha-numerical order by reference designation.
- c. Mechanical parts.

Information given for each part consists of the following:

- a. The Hewlett-Packard part number.
- b. Part number check digit (CD).
- c. The total quantity (Qty) for the entire instrument except for option assemblies.
- d. The description of the part.

e. A typical manufacturer of the part in a five-digit code.

f. The manufacturer's number for the part.

The total quantity for each part is given only once at the first appearance of the part number in the list for each major assembly.

Table 6-1. Part Numbers for Exchange Assemblies

Reference Designation	Description	Part Number*	
		Exchange Assy	New Assy
A1	CPU PCA	E1426-69501	Not available
A2	Acquisition PCA	E1426-69502	Not available

*When ordering extra assemblies for spare parts stock, use new assembly part number only. Exchange orders require return of the defective part.

Table 6-2. Reference Designators and Abbreviations (1 of 2)

REFERENCE DESIGNATIONS

A assembly	E miscellaneous electrical part	P electrical connector (movable portion); plug	U integrated circuit; microcircuit
AT attenuator; isolator; termination	F fuse	Q transistor; SCR; triode thyristor	V electron tube
B fan; motor	FL filter	R resistor	VR voltage regulator; breakdown diode
BT battery	H hardware	RT thermistor	W cable; transmission path; wire
C capacitor	HY circulator	S switch	X socket
CP coupler	J electrical connector (stationary portion); jack	T transformer	Y crystal unit (piezo-electric or quartz)
CR diode; diode thyristor; varactor	K relay	TB terminal board	Z tuned cavity; tuned circuit
DC directional coupler	L coil; inductor	TC thermocouple	
DL delay line	M meter	TP test point	
DS annunciator; signaling device (audible or visual); lamp; LED	MP miscellaneous mechanical part		

ABBREVIATIONS

A ampere	COEF coefficient	EDP electronic data processing	INT internal
ac alternating current	COM common	ELECT electrolytic	kg kilogram
ACCESS accessory	COMP composition	ENCAP encapsulated	kHz kilohertz
ADJ adjustment	COMPL complete	EXT external	k Ω kilohm
A/D analog-to-digital	CONN connector	F farad	kV kilovolt
AF audio frequency	CP cadmium plate	FET field-effect transistor	lb pound
AFC automatic frequency control	CRT cathode-ray tube	F/F flip-flop	LC inductance-capacitance
AGC automatic gain control	CTL complementary transistor logic	FH flat head	LED light-emitting diode
AL aluminum	CW continuous wave	FIL H fillister head	LF low frequency
ALC automatic level control	D/A digital-to-analog	FM frequency modulation	LG long
AM amplitude modulation	dB decibel	FP front panel	LH left hand
AMPL amplifier	dBm decibel referred to 1 mW	FREQ frequency	LIM limit
APC automatic phase control	dc direct current	FXD fixed	LIN linear taper (used in parts list)
ASSY assembly	deg degree (temperature interval or difference)	g gram	lin linear
AUX auxiliary	... $^{\circ}$ degree (plane angle)	GE germanium	LK WASH lock washer
avg average	$^{\circ}$ C degree Celsius (centigrade)	GHz gigahertz	LO low; local oscillator
AWG American wire gauge	$^{\circ}$ F degree Fahrenheit	GL glass	LOG logarithmic taper (used in parts list)
BAL balance	$^{\circ}$ K degree Kelvin	GRD ground(ed)	log logarithm(ic)
BCD binary coded decimal	DEPC deposited carbon	H henry	LPF low pass filter
BD board	DET detector	h hour	LV low voltage
BE CU beryllium copper	diam diameter	HET heterodyne	m metre (distance)
BFO beat frequency oscillator	DIA diameter (used in parts list)	HEX hexagonal	mA milliampere
BH binder head	DIFF AMPL differential amplifier	HD head	MAX maximum
BKDN breakdown	div division	HDW hardware	M Ω megohm
BP bandpass	DPDT double-pole, double-throw	HF high frequency	MEG meg (10 6) (used in parts list)
BPF bandpass filter	DR drive	HG mercury	MET FLM metal film
BRS brass	DSB doublesideband	HI high	MET OX metallic oxide
BWO backward-wave oscillator	DTL diode transistor logic	HP Hewlett-Packard	MF medium frequency; microfarad (used in parts list)
CAL calibrate	DVM digital voltmeter	HPF high pass filter	MFR manufacturer
ccw counter-clockwise	ECL emitter coupled logic	HR hour (used in parts list)	mg milligram
CER ceramic	EMF electromotive force	HV high voltage	MHz megahertz
CHAN channel		Hz Hertz	mH millihenry
cm centimetre		IC integrated circuit	mho mho
CMO cabinet mount only		ID inside diameter	MIN minimum
COAX coaxial		IF intermediate frequency	min minute (time)
		IMPG impregnated	... ' minute (plane angle)
		IN inch	MINAT miniature
		INCD incandescent	mm millimetre
		INCL include(s)	
		INP input	
		INS insulation	

NOTE

All abbreviations in the parts list will be in upper-case.

Table 6-2. Reference Designators and Abbreviations (2 of 2)

MOD modulator	OD outside diameter	PWV peak working voltage	TD time delay
MOM momentary	OH oval head	RC resistance-capacitance	TERM terminal
MOS metal-oxide semiconductor	OP AMPL operational amplifier	RECT rectifier	TFT thin-film transistor
ms millisecond	OPT option	REF reference	TGL toggle
MTG mounting	OSC oscillator	REG regulated	THD thread
MTR meter (indicating device)	OX oxide	REPL replaceable	THRU through
mV millivolt	oz ounce	RF radio frequency	TI titanium
mVac millivolt, ac	Ω ohm	RFI radio frequency interference	TOL tolerance
mVdc millivolt, dc	P peak (used in parts list)	RH round head; right hand	TRIM trimmer
mVpk millivolt, peak	PAM pulse-amplitude modulation	RLC resistance-inductance-capacitance	TSTR transistor
mVp-p millivolt, peak-to-peak	PC printed circuit	RMO rack mount only	TTL transistor-transistor logic
mVrms millivolt, rms	PCM pulse-code modulation; pulse-count modulation	rms root-mean-square	TV television
mW milliwatt	PDM pulse-duration modulation	RND round	TVI television interference
MUX multiplex	pF picofarad	ROM read-only memory	TWT traveling wave tube
MY mylar	PH BRZ phosphor bronze	R&P rack and panel	U micro (10 ⁻⁶) (used in parts list)
μA microampere	PHL Phillips	RWV reverse working voltage	UF microfarad (used in parts list)
μF microfarad	PIN positive-intrinsic-negative	S scattering parameter	UHF ultrahigh frequency
μH microhenry	PIV peak inverse voltage	s second (time)	UNREG unregulated
μmho micromho	pk peak	" second (plane angle)	V volt
μs microsecond	PL phase lock	S-B slow-blow (fuse) (used in parts list)	VA voltampere
μV microvolt	PLO phase lock oscillator	SCR silicon controlled rectifier; screw	Vac volts, ac
μVac microvolt, ac	PM phase modulation	SE selenium	VAR variable
μVdc microvolt, dc	PNP positive-negative-positive	SECT sections	VCO voltage-controlled oscillator
μVpk microvolt, peak	P/O part of	SEMICON semiconductor	Vdc volts, dc
μVp-p microvolt, peak-to-peak	POLY polystyrene	SHF superhigh frequency	VDCW volts, dc, working (used in parts list)
μVrms microvolt, rms	PORC porcelain	SI silicon	V(F) volts, filtered
μW microwatt	POS positive; position(s) (used in parts list)	SIL silver	VFO variable-frequency oscillator
nA nanoampere	POSN position	SL slide	VHF very-high frequency
NC no connection	POT potentiometer	SNR signal-to-noise ratio	Vpk volts, peak
N/C normally closed	p-p peak-to-peak	SPDT single-pole, double-throw	Vp-p volts, peak-to-peak
NE neon	PP peak-to-peak (used in parts list)	SPG spring	Vrms volts, rms
NEG negative	PPM pulse-position modulation	SR split ring	VSWR voltage standing wave ratio
nF nanofarad	PREAMPL preamplifier	SPST single-pole, single-throw	VTO voltage-tuned oscillator
NI PL nickel plate	PRF pulse-repetition frequency	SSB single sideband	VTVM vacuum-tube voltmeter
N/O normally open	PRR pulse repetition rate	SST stainless steel	V(X) volts, switched
NOM nominal	ps picosecond	STL steel	W watt
NORM normal	PT point	SQ square	W/ with
NPN negative-positive-negative	PTM pulse-time modulation	SWR standing-wave ratio	WIV working inverse voltage
NPO negative-positive zero (zero temperature coefficient)	PWM pulse-width modulation	SYNC synchronize	WW wirewound
NRFR not recommended for field replacement		T timed (slow-blow fuse)	W/O without
NSR not separately replaceable		TA tantalum	YIG yttrium-iron-garnet
ns nanosecond		TC temperature compensating	Z ₀ characteristic impedance
nW nanowatt			
OBD order by description			

NOTE

All abbreviations in the parts list will be in upper-case.

MULTIPLIERS

Abbreviation	Prefix	Multiple
T	tera	10 ¹²
G	giga	10 ⁹
M	mega	10 ⁶
k	kilo	10 ³
da	deka	10
d	deci	10 ⁻¹
c	centi	10 ⁻²
m	milli	10 ⁻³
μ	micro	10 ⁻⁶
n	nano	10 ⁻⁹
p	pico	10 ⁻¹²
f	femto	10 ⁻¹⁵
a	atto	10 ⁻¹⁸

Table 6-3. Replaceable Parts

Reference Designator	HP Part Number	C D	Qty	Description	Mfr Code	Mfr Part Number
A1	NONE		1	CPU Printed Circuit Assembly (E1426A)	28480	NONE
A1	E1426-69501		1	CPU Printed Circuit Assembly (Exchange) (repair limited to replacement of following parts)	28480	E1426-69501
A1F1	2110-0699		6	Fuse-Sub Miniature-5A	28480	2110-0699
A1F2	2110-0699			Fuse-Sub Miniature-5A	28480	2110-0699
A1F3	2110-0699			Fuse-Sub Miniature-5A	28480	2110-0699
A1F4	2110-0699			Fuse-Sub Miniature-5A	28480	2110-0699
A1F5	2110-0699			Fuse-Sub Miniature-5A	28480	2110-0699
A1F6	2110-0699			Fuse-Sub Miniature-5A	28480	2110-0699
A1J1	1251-8828		2	Connector-Post 2X20	28480	1251-8828
A1J2	1251-8828			Connector-Post 2X20	28480	1251-8828
A1J3	1251-8106		1	Connector-Post 2X10	28480	1251-8106
A1J4	1250-0257		1	Connector-Sub Miniature	28480	1250-0257
A1P1	1252-1596		2	Connector-Right Angle-96 Pin	28480	1252-1596
A1P2	1252-1596			Connector-Right Angle-96 Pin	28480	1252-1596
A1SP1	3101-2640		1	Switch-Rocker 10 Position 5 V 0.1 A	28480	3101-1596
A1SP2	3101-2243		1	Switch-Rocker 8 Position 5 V 0.1 A	28480	3101-2243
A1SW1	3101-2719		1	Switch-Slide 2 Position 5 V 0.1 A	28480	3101-2719
A2	NONE		1	Acquisition Printed Circuit Assembly	28480	NONE
A2	E1426-69502		1	Acquisition Printed Circuit Assembly (Exchange) (repair limited to replacement of following parts)	28480	E1426-69502
A2J101	1250-0257		2	Connector-Sub Miniature	28480	1250-0257
A2J102	1250-0257			Connector-Sub Miniature	28480	1250-0257
A2J201	1251-8828		2	Connector-Post 2X20	28480	1251-8828
A2J202	1251-8828			Connector-Post 2X20	28480	1251-8828
A2J301	1252-2952		4	Connector-Post 2X12	28480	1252-2952
A2J302	1252-2952			Connector-Post 2X12	28480	1252-2952
A2J303	1252-2952			Connector-Post 2X12	28480	1252-2952
A2J304	1252-2952			Connector-Post 2X12	28480	1252-2952
W1	E1426-61601		2	Cable Assembly-40 Conductor	28480	E1426-61601
W2	E1426-61601			Cable Assembly-40 Conductor	28480	E1426-61601
W3	E1426-61602		3	Cable Assembly 50Ω	28480	E1426-61602
W4	E1426-61602			Cable Assembly 50Ω	28480	E1426-61602
W5	E1426-61602			Cable Assembly 50Ω	28480	E1426-61602
MECHANICAL PARTS						
MP1	E1400-84105		1	Handle-Bottom	28480	E1400-84105
MP2	E1400-84106		1	Handle-Top	28480	E1400-84106
MP3	E1426-00201		1	Panel-Front	28480	E1426-00201
MP4	E1426-00601		1	Shield-Bottom	28480	E1426-00601
MP5	E1426-00602		1	Shield-Top	28480	E1426-00602
AT1	54503-63401		4	Vertical Attenuator	28480	54503-63401
AT2	54503-63401			Vertical Attenuator	28480	54503-63401
AT3	54503-63401			Vertical Attenuator	28480	54503-63401
AT4	54503-63401			Vertical Attenuator	28480	54503-63401
COMMON HARDWARE						
	0515-0430		9	Screw Pan-Head M3.0X.5 Torx T10	00000	Order by Description
	0515-1031		6	Screw Flat-Head M3.0X.5 Torx T10	00000	Order by Description
	0380-3025		1	Stand-off 1/4X19mm M3.0X.5	00000	Order by Description
	0380-3026		1	Stand-off 1/4X29mm M3.0X.5	00000	Order by Description
	54503-25701		7	Nut-Hex-Single Chamfer 5/8-32 THD	28480	Order by Description

See Introduction to this section for ordering information
 * Indicates factory selected value
 † Backdating information in section VII

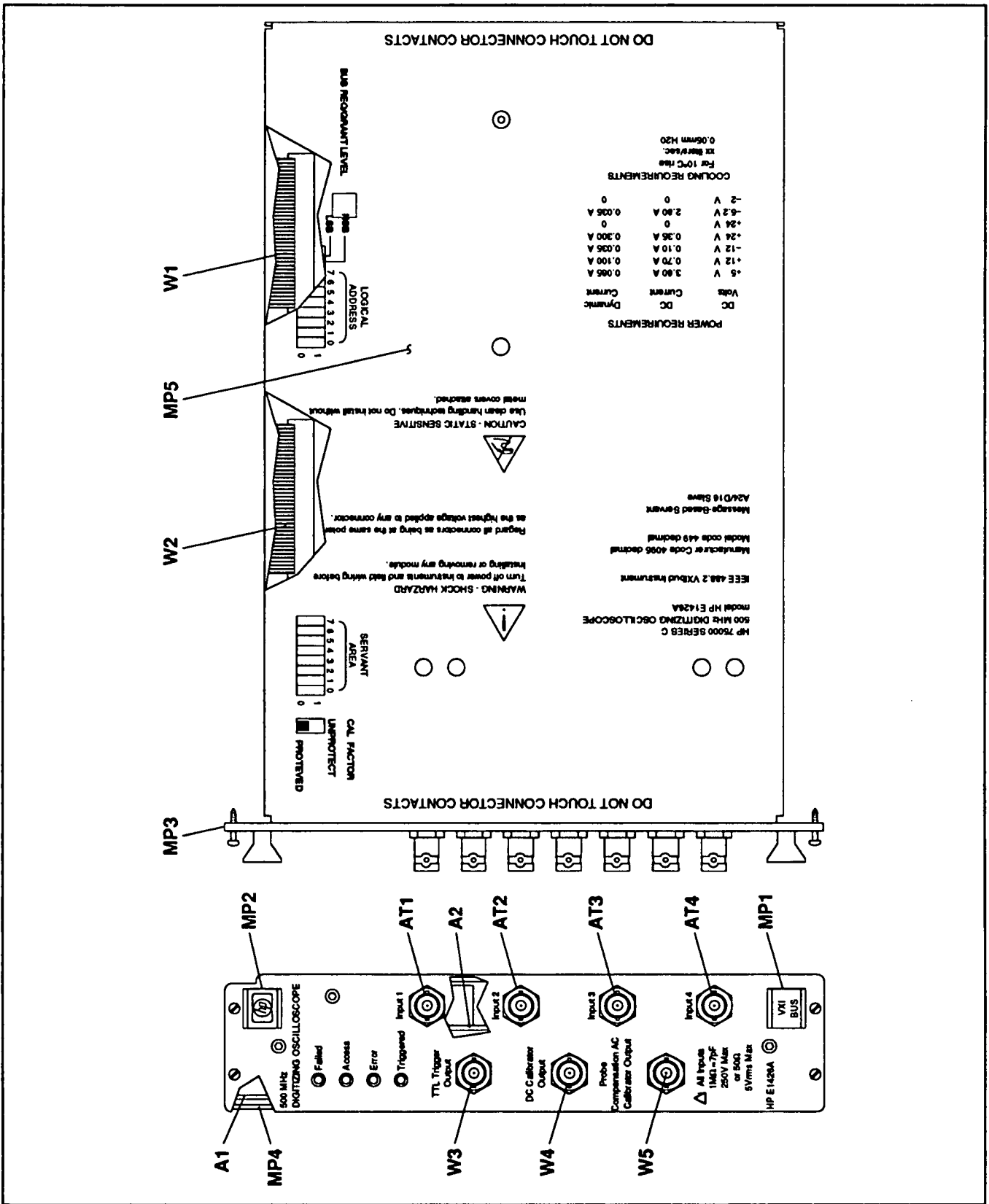

Figure 6-1. Oscilloscope Replaceable Parts

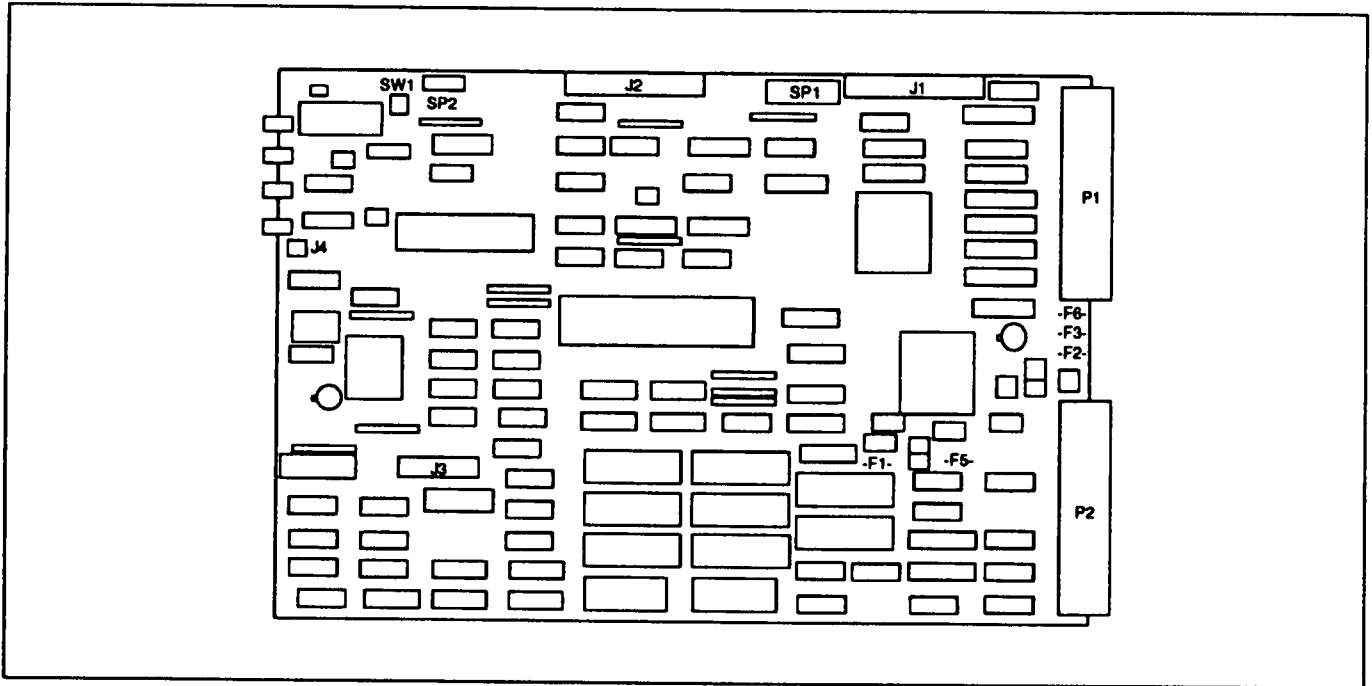

Figure 6-2. A1 CPU PCA Replaceable Parts

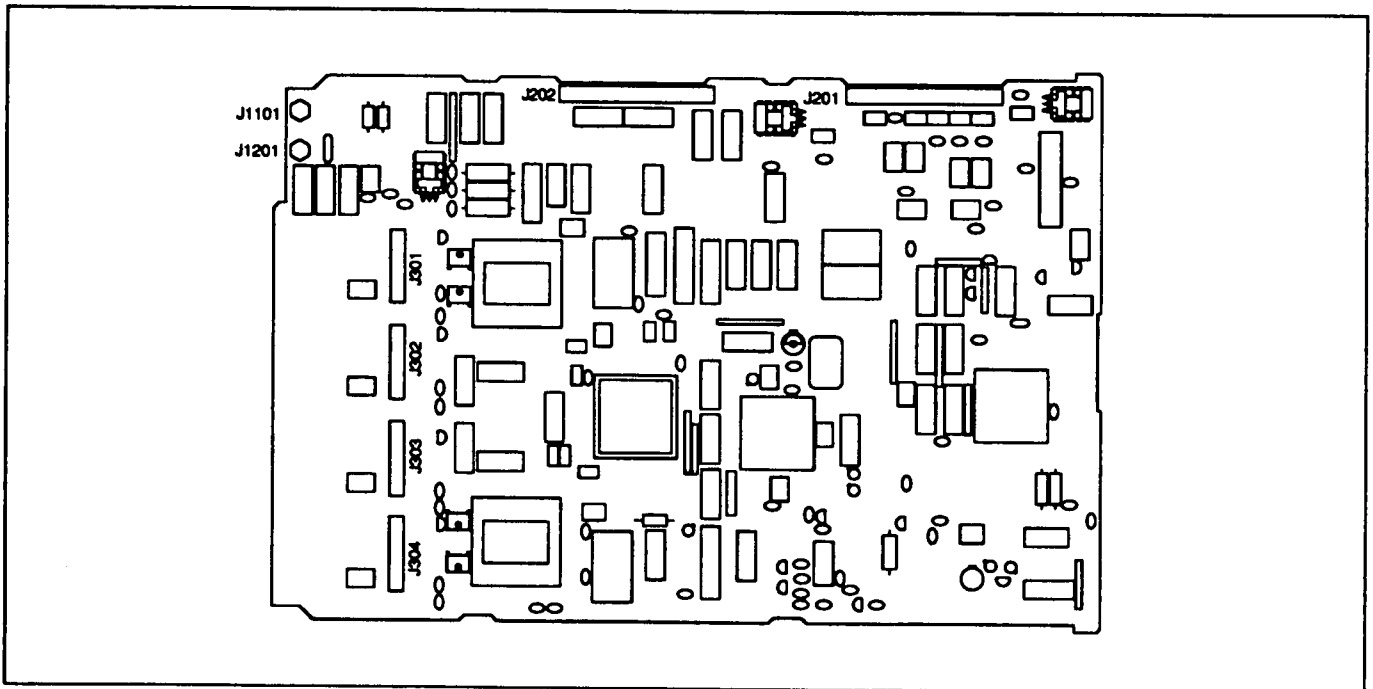

Figure 6-3. A2 Acquisition PCA Replaceable Parts

Table 6-4. Code List of Manufacturers

Mfr Code	Manufacturer Name	Address	Zip Code
00000 28480	ANY SATISFACTORY SUPPLIER HEWLETT-PACKARD COMPANY CORPORATE HEADQUARTERS	PALO ALTO CA	94304

Manual Changes

7-1. Introduction

This section normally contains information for adapting this manual to instruments for which the content does not apply directly. Since this manual does apply directly to instruments having serial numbers listed on the title page, no change information is given here. Refer to **INSTRUMENTS COVERED BY THIS MANUAL** in Chapter 1 for additional important information about serial number coverage.

8-1. Introduction

This chapter contains information for servicing the HP E1426A Oscilloscope. Included are procedures for troubleshooting, repair, disassembly, and re-assembly.

8-2. Safety Considerations

This paragraph contains information, cautions, and warnings which must be followed for your protection and to avoid damage to the equipment when repairing the Oscilloscope.

Warning

Any interruption of the protective (grounding) conductor (inside or outside the instrument) or disconnecting the protective earth terminal will cause a potential shock hazard that could result in personal injury. (Grounding one conductor of a two conductor outlet is not sufficient protection.) In addition, verify that a common ground exists between the unit under test and this instrument prior to energizing either unit.

Whenever it is likely that the protection has been impaired, the instrument must be made inoperative and be secured against any unintended operation.

If this instrument is to be energized via an autotransformer (for voltage reduction) make sure the common terminal is connected to neutral (that is, the grounded side of the mains supply).

Servicing instructions are for use by service-trained personnel only. To avoid dangerous electric shock, do not perform any servicing unless qualified to do so.

Maintenance described in the manual is performed with power supplied to the instrument while protective covers are removed. Energy available at many points may, if contacted, result in personal injury. Where maintenance can be performed without power applied, the power should be removed.

Capacitors inside the instrument may still be charged even if the instrument has been disconnected from its source of supply.

For continued protection against fire hazard, replace the line fuse(s) only with 250V fuse(s) of the same current rating and type (for example, normal blow, time delay, etc.). Do not use repaired fuses or short circuited fuseholders.

Caution

Do not disconnect or remove any modules in the mainframe unless the mainframe is unplugged. Some modules contain devices that can be damaged if the board is removed when the power is on. Several components, including MOS devices, can be damaged by electrostatic discharge. Use conductive foam and grounding straps when servicing is required on sensitive components. Use care when unplugging ICs from high-grip sockets.

8-3. Equipment Required

Equipment required for troubleshooting and repair of the mainframe is listed in Table 1-1, Recommended Test Equipment. Any equipment that satisfies the critical specifications given in the table may be substituted.

Pozidriv Screwdrivers

Many screws in the mainframe appear to be Phillips type, but are not. To avoid damage to the screw head slots, Pozidriv screwdrivers should be used. HP P/N 8710-0899 is the No. 1 Pozidriv and HP P/N 8710-0900 is the No. 2 Pozidriv.

Torx Screwdrivers

Some screws in the mainframe appear to be Hex type, but are not. To avoid damage to the screw heads, Torx screwdrivers must be used. HP 8710-1284 is size T-10.

8-4. Troubleshooting

8-5. General

Oscilloscope problems usually fall into four general categories: turn-on errors, operator errors, instrument performance out of specification, and catastrophic failures. The troubleshooting strategy is different for each category.

- **Turn-on Errors:** An error number (other than "0") returned when an instrument self-test fails indicating that the built-in diagnostic routine has detected some problem. Recycle power and repeat the self-test. If the error repeats, troubleshooting using the procedures in paragraph 8-8.
- **Operator Errors:** Apparent failures often result from operator errors. Refer to the "HP E1426A Users Manual", Appendix B for additional information on these errors.
- **Instrument Performance Out of Specification:** If a parameter is out of limits, use the adjustment procedures in Chapter 5 to correct the problem.
- **Catastrophic Failure :** When a catastrophic failure occurs, troubleshooting using the procedures in paragraph 8-8.

8-6. Service Aids

The following information is provided to assist the technician when performing maintenance on the Oscilloscope.

Assembly, Parts and Cable Locations

For specific assembly/component descriptions and ordering information, refer to table 6-3, "Replaceable parts", in Chapter 6. Chassis and frame parts, as well as mechanical parts (MP's) and cables (W or CBL), are identified in the illustrated parts breakdown (IPB) in Chapter 6.

Test Points and Adjustment Locations

There are no test points for the Oscilloscope. Manual adjustment locations are provided in Chapter 5.

Service Aids on Printed Circuit Boards

Service aids on printed circuit boards include pin numbers, some reference designations, and assembly part numbers.

Other Service Documents

Service Notes, *Manual Updates*, and other service literature are available through Hewlett-Packard. For further information, contact your nearest Hewlett-Packard office.

8-7. Visual Inspection

Visually inspect the Oscilloscope for any signs of abnormal internally generated heat, such as discolored printed circuit boards or components, damaged insulation, or evidence of arcing. Determine and remedy the cause of any such condition.

Switch Settings

Verify the logical address setting is set to the correct setting (factory set at 40).

Verify the bus request/grant level setting is set to the correct setting (factory set at level 3).

Note

Refer to the HP E1426A User's Manual for more information.

Connections

Verify that all connector contacts are not damaged, and that all cable connectors are making positive contact.

- Panel BNC Connectors.
- Backplane connector contacts.
- Ribbon cable connector contacts.

8-8. Troubleshooting Test

Perform the following steps to isolate a malfunction within the Oscilloscope to a user replaceable component.

Note

Chapter 6 contains a list of all user replaceable parts. If a part is not listed, return the defective PCA to Hewlett-Packard for exchange.

1. Perform clear status (*CLS), reset (*RST), then preset (SUMM:PRES) the Oscilloscope.
2. Execute the Oscilloscope self diagnostic using the TEST:TALL command.
3. After the test is complete, read the results in the summary questionable test event register (SUMM:QUES:TEST?).

If "0" is returned, then no error has occurred. Proceed with step 4. If "0" is not returned, query the individual TEST event registers to determine the malfunction. Use the information provided below to help isolate the problem. See Chapter 4 or 6 in the E1426A User's Manual for querying test results in the individual registers.

Test Failure	Probable Cause/Action
Display RAM	Not Applicable
System RAM	A1 CPU PCA malfunction. Return for exchange.
Non-volatile RAM	A1 CPU PCA malfunction. Return for exchange.
Acquisition RAM	Suspect A2 Acquisition PCA malfunction. Check A2 first. Return malfunctioning PCA for exchange.
Logic Trigger	A2 Acquisition PCA malfunction. Return for exchange.
Analog Trigger	A2 Acquisition PCA malfunction. Return for exchange.
Time Base	A2 Acquisition PCA malfunction. Return for exchange.
D/A Converter	A2 Acquisition PCA malfunction. Return for exchange.
A/D Converter	A2 Acquisition PCA malfunction. Return for exchange.

4. Disconnect power and remove Oscilloscope from the mainframe. Separate the A1 and A2 PCA's (see information in this chapter). Use the following information to isolate the problem to a user replaceable part.

Step	Description	Probable Cause/Action
1.	Power Supplies	1. Check A1F1 through A1F6. 2. Check A1P1/P2.
2.	Signal Connection	1. Check all connectors. 2. Check all contacts. 3. Check all cables.
3.	Visual Inspection/Improper Operation	1. Inspect (see next page). 2. Verify connection. 3. Verify proper operation.

5. If malfunction cannot be isolated to a user replaceable component, return the Oscilloscope to Hewlett-Packard for repair.

8-9. Repair and Replacement

8-10. Disassembly and Reassembly

Procedures are provided for disassembly and re-assembly of the following items:

- A1 CPU Circuit Assembly
- A2 Acquisition Circuit Assembly
- AT1-4 Vertical Attenuators
- W3-5 BNC Cable Assemblies

A1 CPU Printed Circuit Assembly

1. Remove the A2 Acquisition PCA (see instructions in this chapter).
2. Disconnect the 50Ω cable (W3).

Caution

Static electricity is a major cause of component failure. To prevent damage to the electrical components in the Digitizing Oscilloscope, observe anti-static techniques whenever working on the Oscilloscope.

3. Remove the 1/4 in. threaded stand-off from the rear center of the board.
4. Remove the Torx T10 pan head screw from the front center of the board.
5. Slide to the rear and remove the A1 CPU PCA.
6. Reverse order to reinstall A1 CPU PCA.

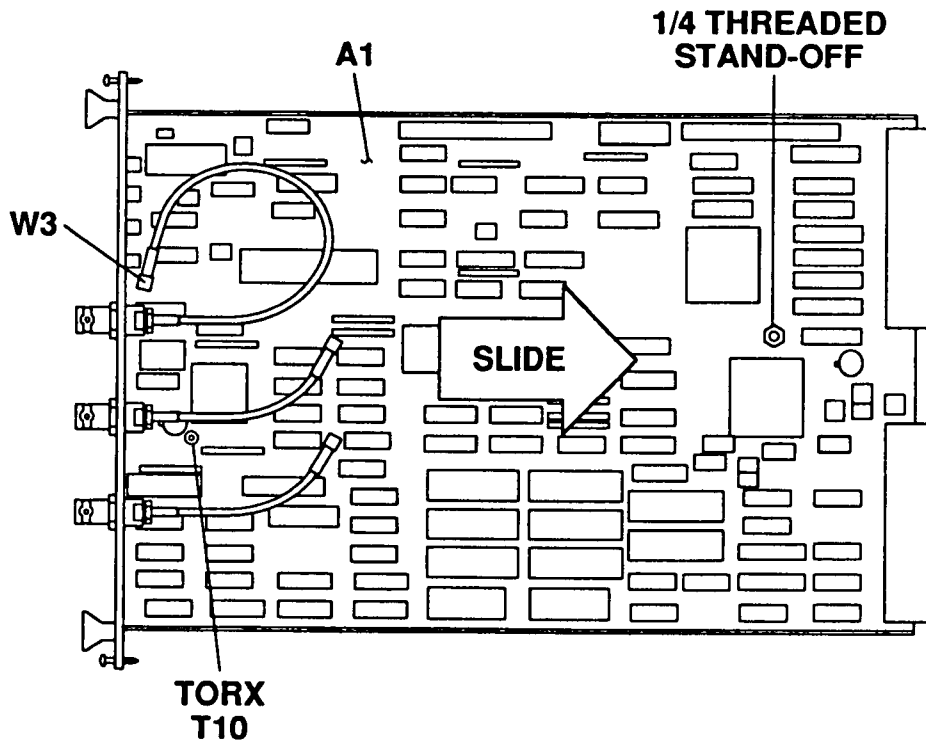

A2 Acquisition Printed Circuit Assembly

1. Place module on its left side and remove the four 5/8 in. nuts from the Input 1-4 connectors.
2. Remove the single Torx T10 flat head screw that is directly above connector INPUT 1.
 - Do not remove the other two screws on the front panel.
3. Remove the Torx T10 flat head screw from the center rear of the right side shield.
4. Remove the two Torx T10 flat head screws from the rear of the unit.
5. Gently lift up the front end of the shield about 3/4 in. to clear the BNC connectors, then slide towards rear and remove shield.

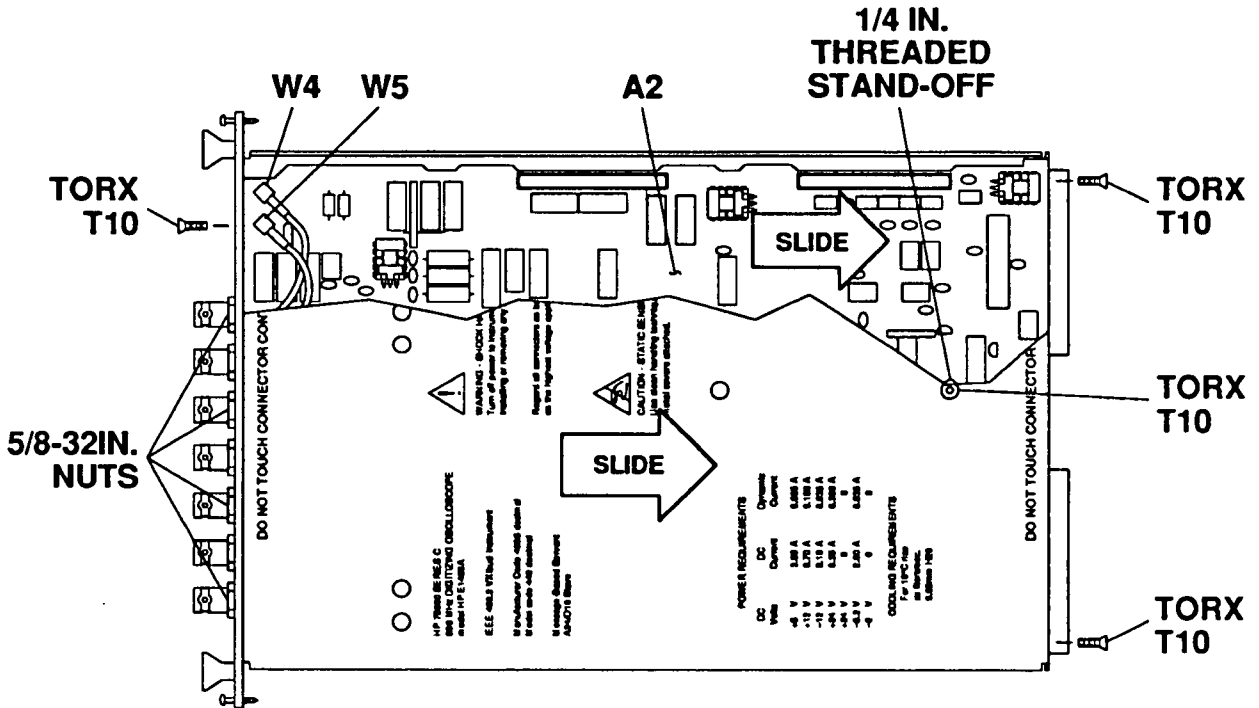

6. Disconnect the following cables:
 - Two ribbon cables (W1, and W2).
 - Disconnect the two 50 ohm cables (W4, and W5).

Caution

Static electricity is a major cause of component failure. To prevent damage to the electrical components in the Digitizing Oscilloscope, observe anti-static techniques whenever working on the Oscilloscope.

7. Remove the 1/4 in. threaded stand-off from the rear center of the board.
8. Slide to the rear and remove the A2 Acquisition PCA.
9. Reverse order to reinstall A2 Acquisition PCA.
 - Do not tighten the front panel BNC nuts until after the right side shield has been installed.

AT1-4 Vertical Attenuators

1. Remove the A2 Acquisition PCA (see instructions in this chapter).
2. Remove the two Torx T10 pan head screws from the circuit side of the board.
3. Lift straight-up to unplug and remove the Vertical Attenuator.
4. Reverse order to reinstall AT1-4 Vertical attenuators.
5. Perform High Frequency Pulse Response Adjustment (see instructions in chapter 5).

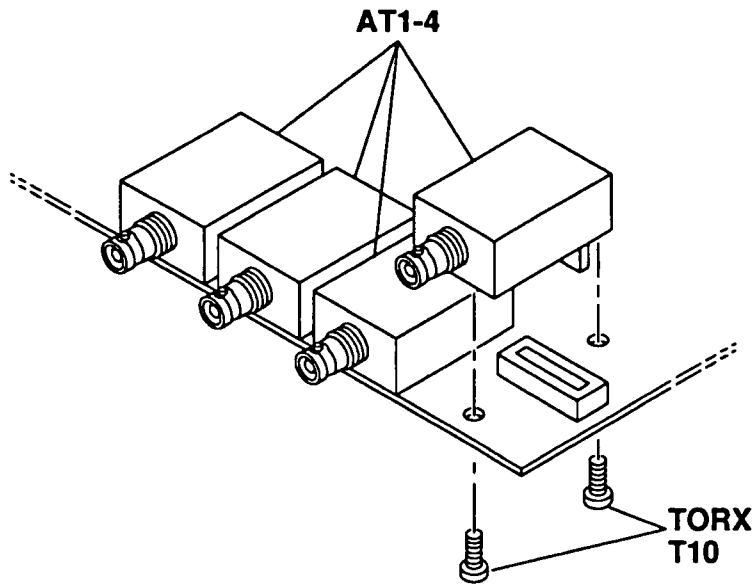

W3-5 BNC Cable Assemblies

1. Remove the A2 Acquisition PCA (see instructions in this chapter).
2. Unplug and mark the SMA connector.
3. Remove the 5/8-32 in. nut.
4. Slide to the rear and remove the BNC Cable Assembly.
5. Reverse order to reinstall the BNC Cable Assembly.

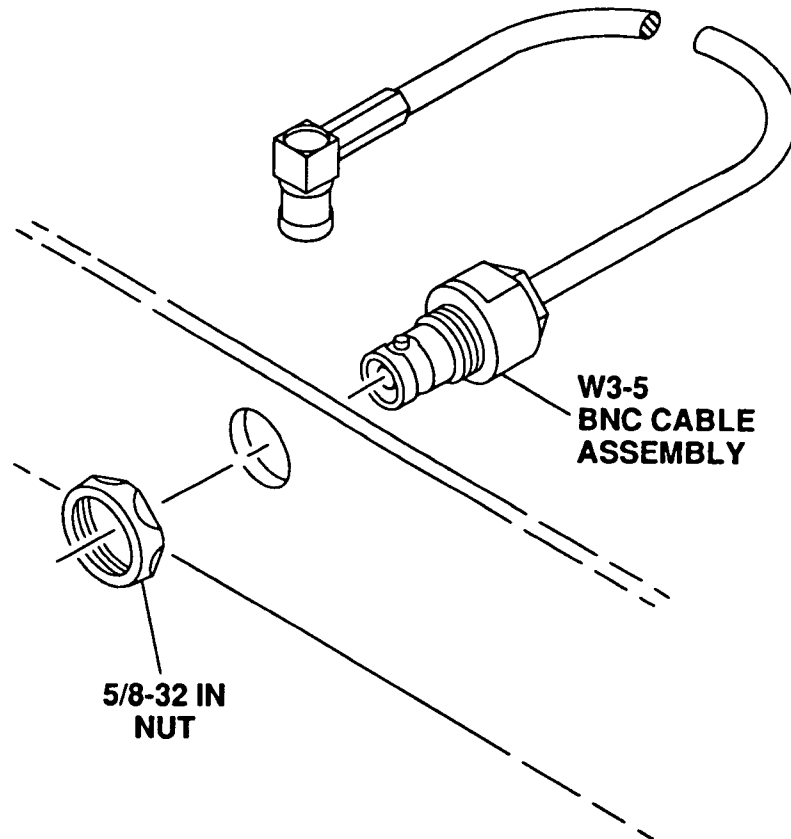

8-11. Repair The following information is provided to assist the technician in repairing the Oscilloscope:

Etched Circuits (Printed Circuit Boards)

The etched circuit boards in the Oscilloscope have plated through holes which make a solder path through to both sides of the insulating material. Soldering can be done from either side of the board with equally good results. When soldering to any circuit board, keep in mind the following recommendations:

1. Avoid unnecessary component unsoldering and soldering. Excessive replacement can result in damage to the circuit board and/or adjacent components.
2. Do not use a high power soldering iron on etched circuit boards. A 38-watt soldering iron is recommended. Excessive heat may lift a conductor or damage the board.

Caution

Do not use a sharp metal object such as an awl or twist drill in the following step. Sharp objects may damage the plated through conductor.

3. Use a suction device or wooden toothpick to remove solder from component mounting holes. When using a suction device make sure that equipment is properly grounded to prevent electrostatic discharge from damaging MOS devices.

Electrostatic Discharge (ESD) Precautions

Electrostatic discharge (ESD) can cause damage to certain assemblies in the Oscilloscope. The damage can range from slight degradation of a parameter to catastrophic failures.

MOS, CMOS, and other static sensitive devices are used in this instrument. They are prone to damage from both static electricity and transient signals. They must be handled carefully. When working on the Oscilloscope assemblies, keep in mind the following recommendations to avoid damaging these sensitive components.

1. Use a static-free work station with a pad of conductive rubber or similar material.
2. After removing assemblies from the Oscilloscope, be sure that they are placed on a conductive surface to guard against ESD damage. Do not stack boards.
3. When removing a MOS or CMOS device from a high grip socket, be careful not to damage it. Avoid removing devices from these sockets with pliers. Instead, use a small screwdriver to pry the device up from one end, slowly pulling it up one pair of pins at a time.
4. Once a MOS or CMOS device has been removed from an assembly, immediately stick it into a pad of conductive foam or other suitable holding medium.

5. When replacing a MOS or CMOS device, ground the foam on which it resides to the instrument before removing it. If a device requires soldering, make sure that the assembly is lying on a pad of conductive material, and that the pad, soldering iron tip, and personnel, are grounded to the assembly. Apply as little heat as possible.
6. Before turning the instrument off, remove any large ac sources that may be driving MOS switches.

Assembly Exchange Program

Table 6-1 lists assemblies that are available on an exchange basis. Refer to the table, and the "Exchange Assemblies" paragraph in Chapter 6 for further information.

Limited Repair Assemblies

Repair of non-exchange assemblies is limited to replacement of selected parts. Replaceable parts (fuses, connectors, hardware) for all Oscilloscope assemblies are listed in table 6-2.

Post Repair Adjustments

Adjustment procedures are provided in Chapter 5.

Post Repair Safety Checks

Visually inspect the Oscilloscope for any signs of abnormal internally generated heat, such as discolored printed circuit boards or components, damaged insulation, or evidence of arcing. Determine and remedy the cause of any such condition.

References**Referenced Publications**

This appendix lists all operating, installation, and service manuals referenced in this manual.

Publication Title	Publication Part Number	Ordering Address
HP E1400B User's Manual	E1400-90005	See Sales and Support Offices listed in the back of this manual
HP E1405A User's Manual	E1405-90001	See Sales and Support Offices listed in the back of this manual
HP E1426A User's Manual	E1426-97002	See Sales and Support Offices listed in the back of this manual
HP E1426A Service Manual	E1426-97003	See Sales and Support Offices listed in the back of this manual



HEWLETT®
PACKARD



Hewlett-Packard
Printed in the USA

